

Appendix C

Liaison with MKC's Public Transport and subsequently Road Safety Team

James Horne

From: Paradine, Kevan <Kevan.Paradine@Milton-Keynes.gov.uk>
Sent: 16 January 2018 10:15
To: James Horne
Subject: RE: Public transport improvements - new employment development on Willen Road

Hello James

Thank you for this, that's fine as all the information should enable an objectively based decision to be made on the matter.

Regards
Kevan.

Kevan Paradine
Senior Road Safety Engineer
T: 01908 252036
E: kevan.paradine@milton-keynes.gov.uk
<http://www.milton-keynes.gov.uk>

Milton Keynes Council | Public Realm Service Group | Synergy Park | Chesney Wold | Bleak Hall | Milton Keynes | MK6 1LY

From: James Horne [mailto:]
Sent: 16 January 2018 09:48
To: Paradine, Kevan
Cc: Simmonds, Stuart; Swannell, Andy; Rebecca Leconte; Matt Tatler; Mark Higgins; Stuart Dunhill; .com; Mark Plowman; Paul James; Douglas Pielage
Subject: [EXT] RE: Public transport improvements - new employment development on Willen Road

Dear Kevan,

Many thanks providing your thoughts of the initial proposals for these bus stops associated with the junction designs. Your comments, and our response below, will form part of the Stakeholder engagement recorded within the 'Walking, Cycling & Horse-Riding Assessment' currently being prepared to inform the design proposals.

1, My initial thoughts are that, purely from a road safety perspective, buses should not wait on the carriageway within this particular highway environment. Traffic volumes will increase; even with a speed limit reduction, speeds may still be high on this road. Specific issues with an on carriageway stop are increased potential for conflict between road users moving out to pass a stationary bus and those approaching from behind at higher speed, also potential for shunts behind a stopped or stopping bus. The frequency of bus services means the risk of conflict will also be quite high.

Vehicle Speeds

Willen Road, both north and south of Marsh End Roundabout, is currently subject to the National Speed Limit (60mph). A speed survey has already been undertaken along both lengths of Willen Road. This survey indicated that the 85th percentile speeds are as follows:-

- Willen Road (Northern Arm) = 41mph;
- Willen Road (Southern Arm) = 49mph;

These results indicate that the 85th percentile speeds are below the current national speed limit (60mph). This suggests that there is currently not a significant speeding issue along Willen Road. **NB** the scheme proposals include reducing the speed limit to 40mph.

Recorded Injury Collision

1No. Injury collisions have been recorded in 3 years along Willen Road (southern length). It is considered that this does not constitute a significant collision problem at this location with the current national speed limits in place.

Traffic Volumes

Given the likely off peak shift patterns of the employment sites on the development, it is considered likely that the increase in traffic volumes, and frequency of bus services, will not affect traffic volumes significantly in peak periods.

Type of Bus Stop Provision i.e. On-carriageway or Lay-by

It is noted that MKC’s Draft document ‘A Highway Guide for Milton Keynes – November 2014’ states that the layout of bus stops provided on roads classified as ‘District Distributors’ (such as Willen Road) should be provided with lay-bys. However, this is primarily for high speed, dual carriageway roads e.g. the Grid Road like the A4146. The scheme proposals are to reduce the speed limit from National Speed Limit (60mph) to 40mph. Therefore, on-carriageway bus stops are more appropriate. The current scheme proposals are more akin to the existing bus stop layouts provided on the A5130 near Poppy Avenue.

Future Collisions

The shunt type collision described above could be a potentially occurrence at any on-carriageway bus stop. Our proposals have the benefit of being one way, thus removing the potential of head on collisions occurring.

Therefore, and after taking the above into consideration, we would conclude that the appropriate style of bus stop associated with the proposed development junction should be ‘on-carriageway’ as currently indicated by our proposals.

Please can we have an updated response from MKC on this issue.

Kind regards,

James Horne

Principal Engineer

For and on behalf of Peter Brett Associates LLP - [Northampton](#)



From: Paradine, Kevan [<mailto:Kevan.Paradine@Milton-Keynes.gov.uk>]
Sent: 22 December 2017 10:27
To: James Horne <[redacted]>
Subject: RE: Public transport improvements - new employment development on Willen Road

Thank you James, you have a good Christmas and new year too.

Regards
Kevan.

Kevan Paradine
Senior Road Safety Engineer
T: 01908 252036
E: kevan.paradine@milton-keynes.gov.uk
<http://www.milton-keynes.gov.uk>

From: James Horne [mailto: [REDACTED]]
Sent: 22 December 2017 10:23
To: Paradine, Kevan
Cc: Paul James
Subject: [EXT] RE: Public transport improvements - new employment development on Willen Road

Thanks Kevan,

Hope you have a good Christmas and new year.

Kind regards,

James Horne

Principal Engineer

For and on behalf of Peter Brett Associates LLP - [Northampton](#)



From: Paradine, Kevan [mailto:Kevan.Paradine@Milton-Keynes.gov.uk]
Sent: 22 December 2017 10:01
To: James Horne < [REDACTED] >
Subject: FW: Public transport improvements - new employment development on Willen Road

Hello James

This is the email I sent to Stuart. The email outlines my reasoning and preference regarding bus stop siting. As we discussed, there are other considerations etc. within the final decision making process.

Regards
Kevan.

Kevan Paradine
Senior Road Safety Engineer
T: 01908 252036
E: kevan.paradine@milton-keynes.gov.uk
<http://www.milton-keynes.gov.uk>

From: Paradine, Kevan
Sent: 21 December 2017 14:56

To: Simmonds, Stuart

Subject: RE: Public transport improvements - new employment development on Willen Road

Hi Stuart

The proposals for the road layout are not clear and the bus stop locations are not shown on the drawing attached to your email. Andy Swannell has since shown me drawings that indicate the bus stops upstream of the new signal junction and I have based my comments on these drawings.

My initial thoughts are that, purely from a road safety perspective, buses should not wait on the carriageway within this particular highway environment. Traffic volumes will increase; even with a speed limit reduction, speeds may still be high on this road. Specific issues with an on carriageway stop are increased potential for conflict between road users moving out to pass a stationary bus and those approaching from behind at higher speed, also potential for shunts behind a stopped or stopping bus. The frequency of bus services means the risk of conflict will also be quite high.

Regards
Kevan.

Kevan Paradine
Senior Road Safety Engineer
T: 01908 252036
E: kevan.paradine@milton-keynes.gov.uk
<http://www.milton-keynes.gov.uk>

Milton Keynes Council | Public Realm Service Group | Synergy Park | Chesney Wold | Bleak Hall | Milton Keynes | MK6 1LY

From: Simmonds, Stuart

Sent: 18 December 2017 15:38

To: Paradine, Kevan

Subject: FW: Public transport improvements - new employment development on Willen Road

Hello Kevin,

The masterplan gives the detail of the Highways works at the junction with the new entrance to the development. Apparently the A422 roundabout is going to be signalised. Thoughts about on carriageway or in laybys.

regards

Stuart Simmonds
Public Transport Technical Lead
T: 01908 252011
E: Stuart.Simmonds@milton-keynes.gov.uk
Visit us online at www.milton-keynes.gov.uk

Milton Keynes Council | Saxon Court | 502 Avebury Boulevard | Milton Keynes | MK9 3HS

From: Rebecca Leconte [<mailto:>]

Sent: 25 October 2017 11:45

To: Simmonds, Stuart

Cc: Stuart Dunhill

Subject: [EXT] Public transport improvements - new employment development on Willen Road

Stuart,

We have been commissioned by Roxhill Developments to provide transport and highways advice to support an outline planning application for a new employment development on Willen Road, south of Newport Pagnell. As part of this, we need to promote public transport access. This email has therefore been prepared to introduce the proposed development and seek initial advice from you on what is required to facilitate public transport access.

Initial correspondence with Andy Swannell at MKC (following a review of our Transport Assessment Scoping Study), suggested that service provision along this route is poor and that contributions are required. We are meeting with Andy and his consultants to discuss the proposals and the scope of the Transport Assessment on **Friday 3rd November**, and it would therefore be useful to have your feedback before then if possible.

Site location

As shown in the attached figures, the development site is located to the south of Newport Pagnell and east of Milton Keynes. It is a triangular piece of land bound to the north by the A422 Monks Way, to the east by Willen Rd, and to the west by the M1. The site forms part of a much larger area of land allocated within the Plan:MK for a mixed residential and employment sustainable urban extension, within Policy SD14 – Milton Keynes East.

Proposed development

As shown in the attached masterplan, the outline development proposals comprise two large B8 warehouse and distribution units with ancillary B1 office use. It is envisaged that the site as a whole would employ approximately 1000 employees. It is likely that the units will operate 24 hours a day and utilise shift patterns (typically 0600-1400, 1400-2200 and 2200-0600 hours), although staff within the ancillary office uses will work more standard office hours.

Forecast number of public transport trips

Based on travel to work data from the 2011 Census, we forecast that approximately 5% of all trips to and from work will be by bus, and 5% will be by train (as part of a multimodal journey involving walking, cycling or bus).

At this stage, we therefore forecast that the development would generate approximately 110 two-way bus passenger trips per day, and 10 two-way bus passenger trips in the peak hours. A similar number of train passenger trips are forecast, and assuming that these then use the bus between the site and the train station (due to the distance from Milton Keynes Central), the development would generate an additional 20 bus passenger trips in the peak hours, and 220 bus passenger trips per day.

Existing bus services

It is understood that the following bus services route along Willen Road past the site (see attached figure):

- Service 1 – between Newton Leys and Newport Pagnell, via MK Central train station.
 - This currently runs every 30 minutes from Monday to Saturday (between approximately 7am and 7pm), and hourly during the evenings (until approximately midnight) and on Sundays.
 - However, from 1 November, the service will terminate at MK Central during the day, and only run past the site and to/from Newport Pagnell in the evenings at an hourly frequency.
- Service C10 – between MK Central rail station and Bedford bus station, via Newport Pagnell
 - This currently stops on Willen Road hourly from Monday to Friday (between approximately 6am and 7pm).

Proposed mitigation

As part of the proposed development, it is proposed to provide new bus stops on Willen Road, with shelters and timetable information (subject to land availability and taking into account the Redway route that is also being proposed as part of the development).

It is also proposed to provide funding to improve the frequency of the bus service along Willen Road (with current focus on service 1) to facilitate access and allow the timetable to coincide with shift changeover times.

With the above context, we would appreciate your advice on likely contributions to secure suitable public transport connections to and from the site, and whether this would be via improvements to Service 1, or via improvements to/the diversion of another service. If possible, please could you get back to me before Friday 3rd November?

I trust that the above provides a useful summary of the development, but if you have any questions or require further information, please do not hesitate to contact me.

Regards

Rebecca Leconte

Associate Director – ADC Infrastructure Limited

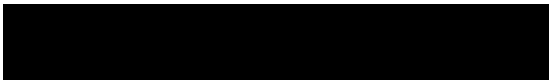

www.ADCInfrastructure.com

Western House, Western Street, Nottingham, NG1 3AZ



Visit the Milton Keynes Council web site at <http://www.milton-keynes.gov.uk>

Please consider the environment and don't print this email unless you really need to

**** This email and any attachments hereto are strictly confidential and intended solely for the addressee. It may contain information which is privileged. If you are not the intended addressee, you must not disclose, forward, copy or take any action in reliance of this email or attachments. If you have received this email in error, please delete it and notify us as soon as possible.

The anti-virus software used by Milton Keynes Council is updated regularly in an effort to minimise the possibility of viruses infecting our systems. However, you should be aware that there is no absolute guarantee that any files attached to this email are virus free.****

This message has been scanned for viruses by Websense

—

*This email and any attachments are **confidential** and protected by **copyright**. If you receive it in error, please notify us immediately and remove it from your system. Peter Brett Associates LLP (PBA) is a limited liability partnership registered in England and Wales. The terms Partner and Member refer to a member of PBA and a list is open for inspection at its registered office. Registered no: OC334398. VAT no: GB115143456. Registered office: Caversham Bridge House, Waterman Place, Reading, RG1 8DN. T: +44 (0) 0118 950 0761, Email *

Visit the Milton Keynes Council web site at <http://www.milton-keynes.gov.uk>

Please consider the environment and don't print this email unless you really need to

**** This email and any attachments hereto are strictly confidential and intended solely for the addressee. It may contain information which is privileged. If you are not the intended addressee, you must not disclose, forward, copy or take any action in reliance of this email or attachments. If you have received this email in error, please delete it and notify us as soon as possible.

The anti-virus software used by Milton Keynes Council is updated regularly in an effort to minimise the possibility of viruses infecting our systems. However, you should be aware that there is no absolute guarantee that any files attached to this email are virus free.****

*This email and any attachments are **confidential** and protected by **copyright**. If you receive it in error, please notify us immediately and remove it from your system. Peter Brett Associates LLP (PBA) is a limited liability partnership registered in England and Wales. The terms Partner and Member refer to a member of PBA and a list is open for inspection at its registered office. Registered no: OC334398. VAT no: GB115143456. Registered office: Caversham Bridge House, Waterman Place, Reading, RG1 8DN. T: +44 (0) 0118 950 0761, Email [REDACTED]*

Visit the Milton Keynes Council web site at <http://www.milton-keynes.gov.uk>

Please consider the environment and don't print this email unless you really need to

**** This email and any attachments hereto are strictly confidential and intended solely for the addressee. It may contain information which is privileged. If you are not the intended addressee, you must not disclose, forward, copy or take any action in reliance of this email or attachments. If you have received this email in error, please delete it and notify us as soon as possible.

The anti-virus software used by Milton Keynes Council is updated regularly in an effort to minimise the possibility of viruses infecting our systems. However, you should be aware that there is no absolute guarantee that any files attached to this email are virus free.****

Appendix D

Appendix D

Liaison with MKC's Senior Transport Planner – Cycling and Events Management

James Horne

From: James Horne
Sent: 02 February 2018 16:09
To: 'Randle, Sara'
Cc: 'andy.swannell@milton-keynes.gov.uk'; Paul James; Douglas Pielage
Subject: FW: RE: Newport Pagnell - Proposed Highway Improvement Scheme

Dear Sara,

Many thanks for providing your thoughts of the initial proposals for these junction designs. Your comments, and our response below, will form part of the Stakeholder Engagement recorded within the 'Walking, Cycling & Horse-Riding Assessment' currently being prepared to inform the design proposals.

1, The proposed Redway linkages are inefficient and indirect. To reach Marsh End Road from the existing redway on the H4 Danstead Way would require three road crossings including two major junctions and six separate stages in this current proposal. (A potential unnecessary delay of 3 minutes to a simple 6 minute journey.) I can see no reason why the Redway switches from the west side of Willen Road to the east side, creating an unattractive and inefficient route for cyclists. At either end, existing Redways and links are on the west side, alternating sides like this is not ideal.

The primary reasons for the proposed Redways is to provide employees working at the new development with off carriageway pedestrian / cyclist access to the site:-

- From Milton Keynes – connecting the existing facilities on the western side of Willen Road (at the Tongwell Roundabout) to the Development, without the need to cross Willen Road;
- From Newport Pagnell – connecting the existing facilities on the eastern side of the Willen Road / Marsh End Road junction, to the Development, providing Toucan Style controlled crossings across the A422 arm of the Marsh End Roundabout (at the location of 3No. Recorded Injury Collisions involving cyclists), then across Willen Road itself at the development signalised junction;
- This, along with physical constraints (such as the available land within the highway boundary) is the reason why these proposed facilities are being provided on differing sides of Willen Road;

When considering cyclists travelling along the length of Willen Road, from Milton Keynes to Newport Pagnell, we note the following benefits are being provided by this scheme:-

- The speed limit along Willen Road, from the Tongwell Roundabout to Marsh End Road, is being to be reduced from National Speed Limit (60mph) to 40mph. Therefore, any cyclist choosing to remain within the carriageway will benefit from lower motorised vehicle speeds;
- Dropped kerbs and cycle road markings have been indicated prior to the stop lines on Willen Road to allow cyclists the opportunity to exit the carriageway prior to both signalised junctions, and join the off carriageway Redway facilities;
- The timings of the controlled crossing point are being reviewed in to order to provide appropriate consideration to cyclists and pedestrians, to reduce journey time. This will also be subject to detailed design;
- The Marsh End Road junction is no longer a roundabout (this junction types has a higher frequency of collisions involving cyclist) and is now a fully signalised roundabout;
- Any cyclist currently travelling from Milton Keynes to Newport Pagnell (and vice versa) is doing so within the carriageway, and would therefore be considered to be an experienced, confident cyclist, who would traditionally choose to remain within the carriageway (even if off carriageway facilities are provided). This scheme provides all types of cyclist with options;

2, There's no indication of how the Redway links to any existing cycle facilities on Marsh End road. There is only one short section of Redway in this area, just north of Tongwell Lane, although Tongwell Lane is traffic free and is also considered to be a good facility of cyclists. Any new Redways would need to link to one of these two facilities and introduce yet another road crossing; unless you would also be willing to upgrade the existing footway in front of the football club to full Redway and create shared use access to Riverside Meadow.

Once additional topographical survey has been obtained for the Willen Road / Marsh End Road junction, the scheme proposals will be updated to indicate how the proposed Redway on the eastern side of Willen Road will connect with the existing facilities at this location, notably:-

- Tongwell Lane;
 - The uncontrolled crossing point north of Tongwell Lane; and
 - The existing signed shared use footway / cycle track on the eastern side of Willen Road (existing 30mph length) adjacent to the Sports Ground;
-

3, Redways are 3 metres wide and on a road with this speed limit a verge is required of at least 1 metre. In the section north of Marsh End roundabout you have indicated the width is only 1.9 metres with no verge. This is not acceptable.

MKC does not currently have its own published highway design guide / standards. However, from a review of a Draft copy of MKC's 'A Highway Guide for Milton Keynes – November 2014', Fig 1 and Table 3.12 have classified Willen Road, H3 Monks Way and the A422 as 'District Distributors', and the appropriate design standards as being the Design Manual for Roads and Bridges (DMRB). This has subsequently been confirmed by MKC's Highway Authority.

The design parameters of the proposed Redways have been determined following a review of the following documents:-

- Design Manual for Roads and Bridges (DMRB):-
 - TA 90/05 – 'The Geometric Design of Pedestrian, Cycle and Equestrian Routes';
 - TA 91/05 – 'Provision for Non-Motorised Users';
 - Interim Advice Note 195/16 – 'Cycle Traffic and the Strategic Road Network';
- Local Transport Note 2/95 – 'The Design of Pedestrian Crossings';
- Local Transport Note 1/12 – 'Shared Use Routes for Pedestrians and Cyclist';
- DfT's Guidance on the Use of Tactile Paving Surfaces;
- A Highway Guide for Milton Keynes – November 2014 DRAFT;

As you have noted, 3m wide Redways with 1m wide buffer zones are being provided adjacent to the 40mph carriageway for the majority of the scheme proposals. However, over a short length (60m approx.), the proposed Redway on the eastern side of Willen Road (north of the Marsh End Roundabout), reduces to 2m (approx.) and is without a buffer zone. This is due to insufficient room to accommodate the increased carriageway width, as well as a standard Redway layout, within the extents of the existing highway boundary at this location.

Therefore, a short section of Redway with reduced width is being proposed, in accordance with the ethos of the DMRB, which promotes the provision of pedestrian and cyclist facilities along entire routes, even if short sections are below desirable widths. Also, Para 7.31 of LTN 1/12 which states:-

Para 7.31 *"It might not always be possible to meet the minimum recommendations for the route as a whole. In this case, practitioners need to consider whether a new sub-standard facility is better than none. For example, on lightly used routes, especially rural shared use routes that avoid high speed roads which have no specific provision for pedestrians or cyclists, a narrow route might represent a considerable improvement on existing conditions."*

Employees will be travelling to the site in order to get to work, or return home, and as a consequence they are likely to be travelling in the same direction.

4, Any vertical street furniture etc should be set back 0.5 metres from the Redway. Exceptions would be on the bridge.

Noted.

5, The approaches of the Redways from the north to Marsh End roundabout and from the south to the junction with the new development access have very poor alignment and do not allow the user to scan for vehicles approaching from behind.

The approaches to the controlled crossings have been provided within the land available. We agreed that the current alignments of the footway / cycle tracks do not provide cyclists with the ability to observe oncoming traffic prior to deciding whether to cross or not before reaching the controlled crossing. However, given the nature of the adjacent carriageways, particularly the H3 Monks Way and A422, we would suggest that an alignment that guides you

to the controlled crossing points and makes you slow down / stop, in order to use the Toucan style controlled crossing points, is more appropriate in this instance.

6, Bus stop placement introduces conflict with users travelling along the Redways. A 'floating bus stop' configuration could be considered.

The scheme proposals will be updated to indicate the alignment of the Redways being taken around the back of the Bus Shelters, in order to reduce the potential conflict between cyclists and pedestrians entering / exiting buses.

I trust the above is clear, however, please contact me to discuss further as required.

Kind regards,

James Horne

Principal Engineer

For and on behalf of Peter Brett Associates LLP - [Northampton](#)



From: Randle, Sara [<mailto:Sara.Randle@milton-keynes.gov.uk>]

Sent: 20 December 2017 15:39

To: Douglas Pielage <[redacted]>

Cc: James Horne <[redacted]>; Swannell, Andy <Andy.Swannell@Milton-keynes.gov.uk>

Subject: RE: Newport Pagnell - Proposed Highway Improvement Scheme

Dear Douglas,

Many thanks for your email. I have taken a look at the plans and have the following comments:

- The proposed Redway linkages are inefficient and indirect. To reach Marsh End Road from the existing redway on the H4 Danstead Way would require three road crossings including two major junctions and six separate stages in this current proposal. (A potential unnecessary delay of 3 minutes to a simple 6 minute journey.) I can see no reason why the Redway switches from the west side of Willen Road to the east side, creating an unattractive and inefficient route for cyclists. At either end, existing Redways and links are on the west side, alternating sides like this is not ideal.
- There's no indication of how the Redway links to any existing cycle facilities on Marsh End road. There is only one short section of Redway in this area, just north of Tongwell Lane, although Tongwell Lane is traffic free and is also considered to be a good facility of cyclists. Any new Redways would need to link to one of these two facilities and introduce yet another road crossing; unless you would also be willing to upgrade the existing footway in front of the football club to full Redway and create shared use access to Riverside Meadow.
- Redways are 3 metres wide and on a road with this speed limit a verge is required of at least 1 metre. In the section north of Marsh End roundabout you have indicated the width is only 1.9 metres with no verge. This is not acceptable.

- Any vertical street furniture etc should be set back 0.5 metres from the Redway. Exceptions would be on the bridge.
- The approaches of the Redways from the north to Marsh End roundabout and from the south to the junction with the new development access have very poor alignment and do not allow the user to scan for vehicles approaching from behind.
- Bus stop placement introduces conflict with users travelling along the Redways. A 'floating bus stop' configuration could be considered.

If you have any queries, please get in touch.

Kind regards
Sara

Sara Randle
Senior Transport Planner - Cycling and Events Management
T: 01908 254334
E: Sara.Randle@milton-keynes.gov.uk
W: <http://www.milton-keynes.gov.uk/cycling>
Milton Keynes Council | Transport Policy | Saxon Court | 502 Avebury Boulevard | Central Milton Keynes | MK9 3HS



From: Douglas Pielage [<mailto:> [REDACTED]]
Sent: 18 December 2017 14:31
To: Randle, Sara
Cc: Cycling; James Horne
Subject: [EXT] Newport Pagnell - Proposed Highway Improvement Scheme

Dear Sara,

We have been passed your details as a point of contact regarding obtaining an opinion from MKC on Walking and Cycling provisions associated with highway improvement schemes.

We are currently working on the design of a new 4 arm signalised junction to be provided on Willen Road to serve a proposed commercial development (western arm), as well as maintain access to the existing farm and residential buildings (eastern arm) known as 'Glenfield' (refer to Draft Drawing 38748/100/007). The existing H3 Monks Way / A422 / Willen Road 4 arm roundabout is also proposed to be increased in size and signalised, in order to accommodate the likely increase in traffic flows generated by a proposed commercial development (refer to Draft Drawing 38748/100/008).

These proposals are being developed by the 'Walking, Cycling & Horse-Riding Assessment' process as detailed by HD 42/17 – 'Walking, Cycling & Horse-Riding Assessment and Review' (WCHAR).

The scheme objectives include improving conditions for walking and cycling as the current route has limited facilities and connections for Non-Motorised Users (NMUs). This is likely to include:-

- Off carriageway shared use footway / cycle track (Redways);
- Toucan style controlled crossings at the 2No new signalised junctions;
- 2No. new bus stops required to serve the development;

The proposed Redway will allow Pedestrians and Cyclists to travel to and from the proposed development along Willen Road. These facilities will also connect:-

- The existing Redway at the Tongwell Roundabout (southern end of Willen Road);
- To the existing Redway adjacent to Marsh End Road (northern end of Willen Road);

This will take the form of a 3m wide (whenever possible) shared use Redway.

We would be grateful to receive comments from MKC on this proposal, from a walking and cycling point of view, to inform the WCHAR process.

Please can you contact me to discuss further.

Kind Regards,

Douglas Pielage

Graduate Engineer

For and on behalf of Peter Brett Associates LLP - [Northampton](#)

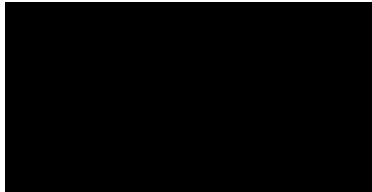

*This email and any attachments are **confidential** and protected by **copyright**. If you receive it in error, please notify us immediately and remove it from your system. Peter Brett Associates LLP (PBA) is a limited liability partnership registered in England and Wales. The terms Partner and Member refer to a member of PBA and a list is open for inspection at its registered office. Registered no: OC334398. VAT no: GB115143456. Registered office: Caversham Bridge House, Waterman Place, Reading, RG1 8DN. T: +44 (0) 0118 950 0761, Email info@peterbrett.com.*

Visit the Milton Keynes Council web site at <http://www.milton-keynes.gov.uk>

Please consider the environment and don't print this email unless you really need to

**** This email and any attachments hereto are strictly confidential and intended solely for the addressee. It may contain information which is privileged. If you are not the intended addressee, you must not disclose, forward, copy or take any action in reliance of this email or attachments. If you have received this email in error, please delete it and notify us as soon as possible.

The anti-virus software used by Milton Keynes Council is updated regularly in an effort to minimise the possibility of viruses infecting our systems. However, you should be aware that there is no absolute guarantee that any files attached to this email are virus free.****

This message has been scanned for viruses by [Websense](#)

Kind regards,

James Horne

Principal Engineer



APPENDIX G

TEMPRO OUTPUT

Dataset Version: 72
Result Type: Trip ends by time period
Base Year: 2018
Future Year: 2023
Trip Purpose Group: All purposes
Time Period: Weekday AM peak period (0700 - 0959)
Trip End Type: Origin/Destination
Alternative Assumptions Applied: No

Growth Factor

Area Description		All purposes	
Level	Name	Origin	Destination
E02003460	Milton Keynes 002	1.0683	1.0569

Future Year - Base Year

Area Description		All purposes	
Level	Name	Origin	Destination
E02003460	Milton Keynes 002	211	131

Base Year

Area Description		All purposes	
Level	Name	Origin	Destination
E02003460	Milton Keynes 002	3,090	2,305

Future Year

Area Description		All purposes	
Level	Name	Origin	Destination
E02003460	Milton Keynes 002	3,301	2,436

Level Area Local Growth Figure
 E02003460 Milton Keynes 002 1.078270911

Dataset Version: 72
Result Type: Trip ends by time period
Base Year: 2018
Future Year: 2023
Trip Purpose Group: All purposes
Time Period: Weekday PM peak period (1600 - 1859)
Trip End Type: Origin/Destination
Alternative Assumptions Applied: No
 NTM: All Road

Growth Factor

Area Description		All purposes	
Level	Name	Origin	Destination
E02003460	Milton Keynes 002	1.0612	1.0700

Future Year - Base Year

Area Description		All purposes	
Level	Name	Origin	Destination
E02003460	Milton Keynes 002	158	203

Base Year

Area Description		All purposes	
Level	Name	Origin	Destination
E02003460	Milton Keynes 002	2,574	2,900

Future Year

Area Description		All purposes	
Level	Name	Origin	Destination
E02003460	Milton Keynes 002	2,732	3,103

Level Area Local Growth Figure
 E02003460 Milton Keynes 002 1.081315154

APPENDIX H

LINSIG RESULTS

Full Input Data And Results

User and Project Details

Project:	Willen Road, Newport Pagnell
Title:	M1 Junction 14 / Northfields Roundabout Model
Location:	
Additional detail:	
File name:	M1 Junction 14_Northfields Roundabout (Linked Existing Model) V7.lsg3x
Author:	
Company:	ADC Infrastructure Limited
Address:	Western House, Western Street, Nottingham NG1 3AZ

Network Layout Diagram

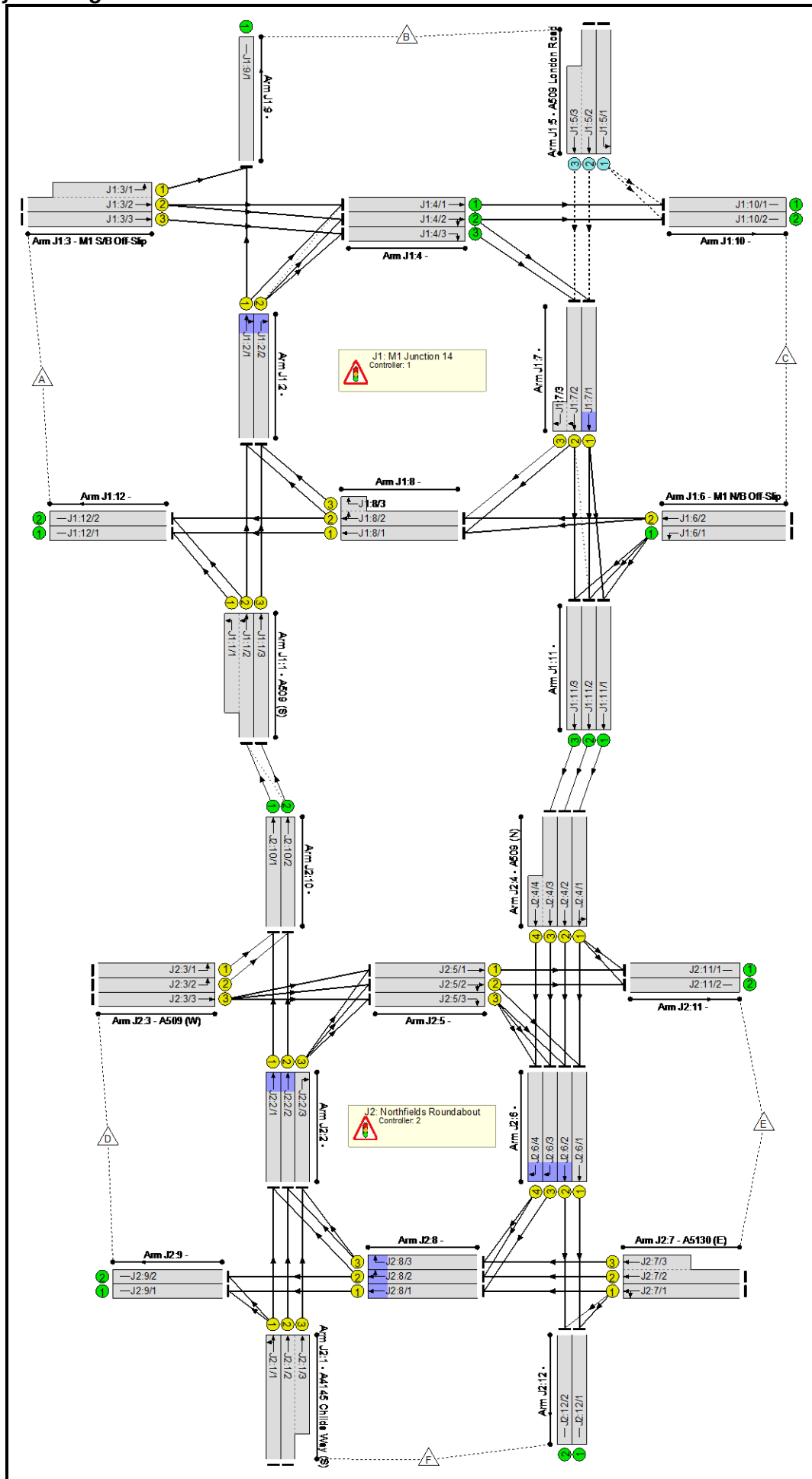

C1
Phase Diagram

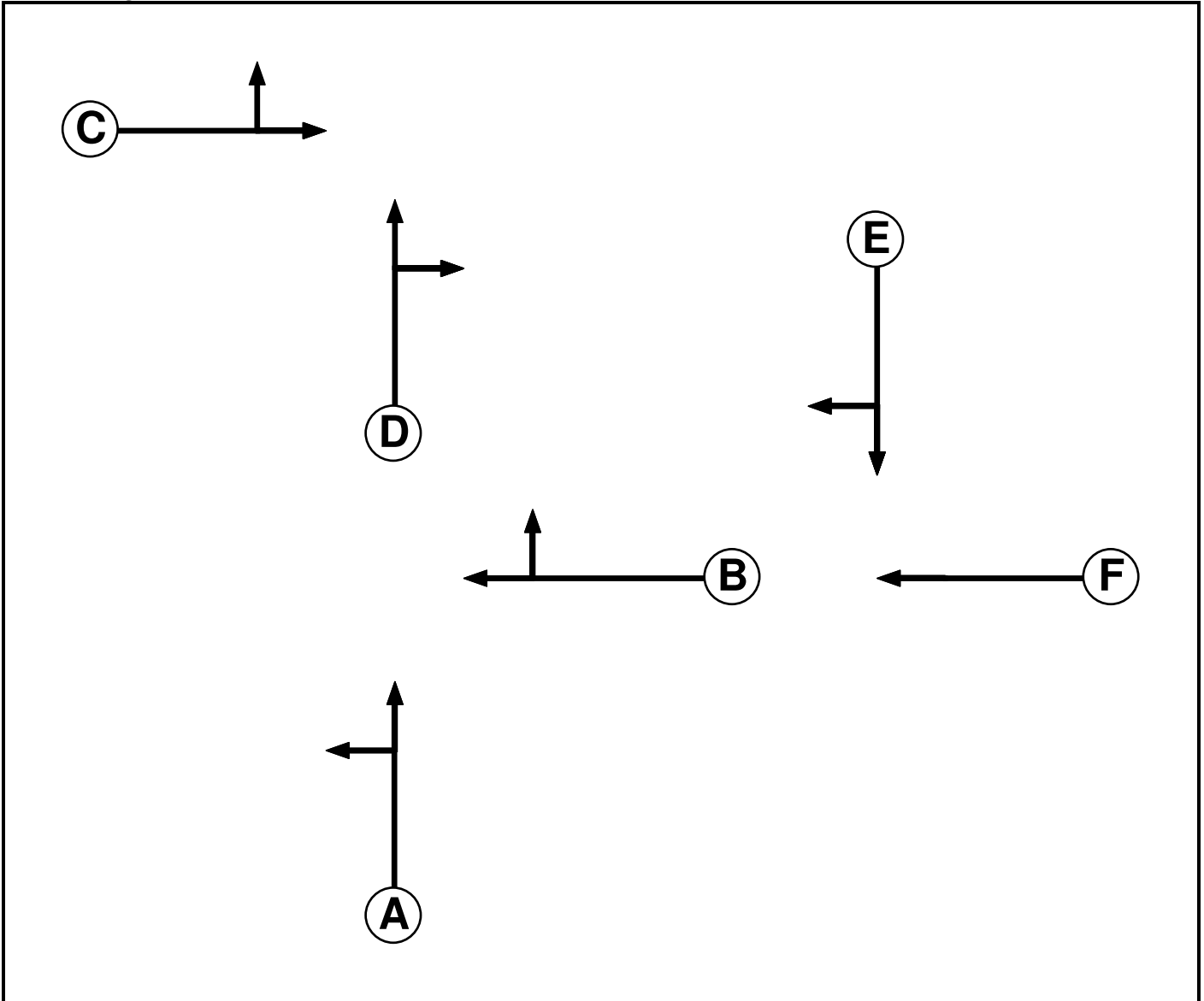

Phase Input Data

Phase Name	Phase Type	Stage Stream	Assoc. Phase	Street Min	Cont Min
A	Traffic	1		7	7
B	Traffic	1		7	7
C	Traffic	2		7	7
D	Traffic	2		7	7
E	Traffic	3		7	7
F	Traffic	3		7	7

Phase Intergrens Matrix

		Starting Phase					
		A	B	C	D	E	F
Terminating Phase	A	6	-	-	-	-	-
	B	6	-	-	-	-	-
	C	-	-	6	-	-	-
	D	-	-	6	-	-	-
	E	-	-	-	-	6	-
	F	-	-	-	-	6	-

Phases in Stage

Stream	Stage No.	Phases in Stage
1	1	A
1	2	B
2	1	C
2	2	D
3	1	F
3	2	E

Stage Diagram

Stage Stream: 1

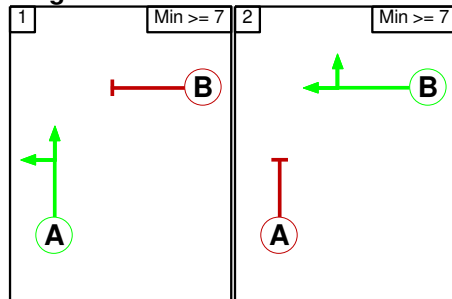

Stage Stream: 2

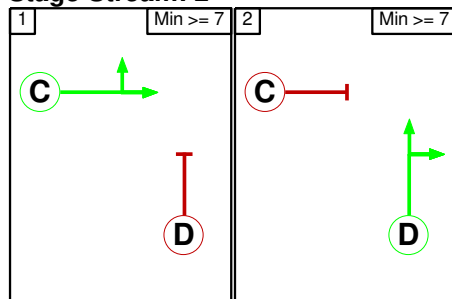

Stage Stream: 3

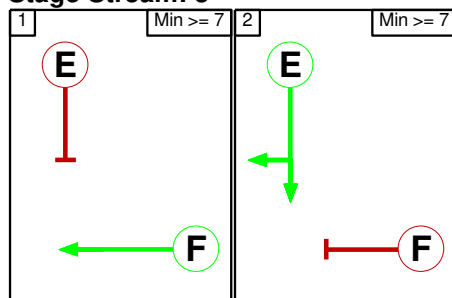

Phase Delays

Stage Stream: 1

Term. Stage	Start Stage	Phase	Type	Value	Cont value
There are no Phase Delays defined					

Stage Stream: 2

Term. Stage	Start Stage	Phase	Type	Value	Cont value
There are no Phase Delays defined					

Stage Stream: 3

Term. Stage	Start Stage	Phase	Type	Value	Cont value
There are no Phase Delays defined					

Prohibited Stage Change

Stage Stream: 1

		To Stage	
		1	2
From Stage	1		6
	2	6	

Stage Stream: 2

		To Stage	
		1	2
From Stage	1		6
	2	6	

Stage Stream: 3

		To Stage	
		1	2
From Stage	1		6
	2	6	

C2
Phase Diagram

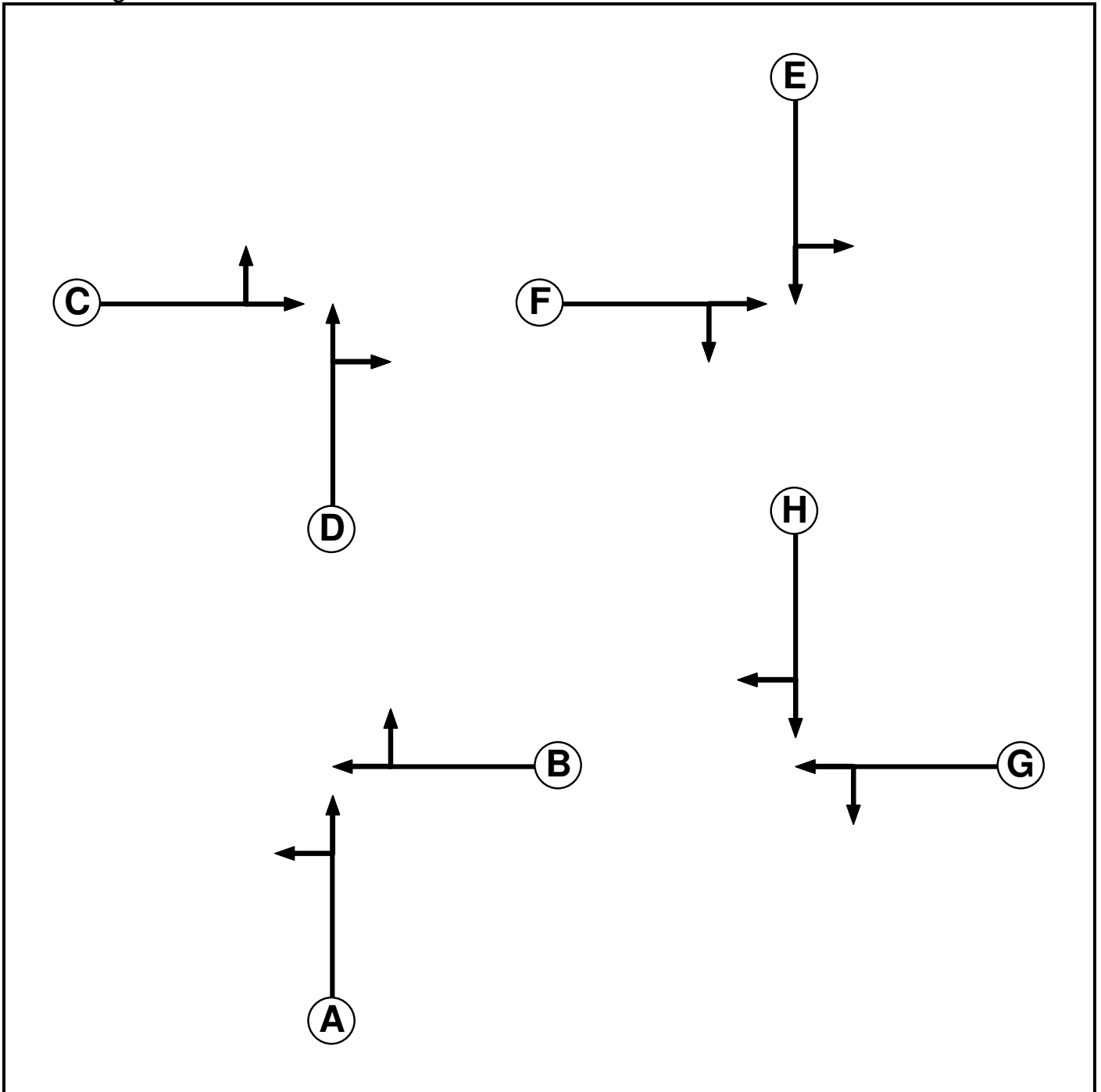

Phase Input Data

Phase Name	Phase Type	Stage Stream	Assoc. Phase	Street Min	Cont Min
A	Traffic	1		7	7
B	Traffic	1		7	7
C	Traffic	2		7	7
D	Traffic	2		7	7
E	Traffic	3		7	7
F	Traffic	3		7	7
G	Traffic	4		7	7
H	Traffic	4		7	7

Phase Intergrens Matrix

		Starting Phase							
		A	B	C	D	E	F	G	H
Terminating Phase	A	6	-	-	-	-	-	-	-
	B	6	-	-	-	-	-	-	-
	C	-	-	6	-	-	-	-	-
	D	-	-	6	-	-	-	-	-
	E	-	-	-	-	6	-	-	-
	F	-	-	-	-	6	-	-	-
	G	-	-	-	-	-	-	6	-
	H	-	-	-	-	-	-	6	-

Phases in Stage

Stream	Stage No.	Phases in Stage
1	1	A
1	2	B
2	1	C
2	2	D
3	1	E
3	2	F
4	1	G
4	2	H

Stage Diagram

Stage Stream: 1

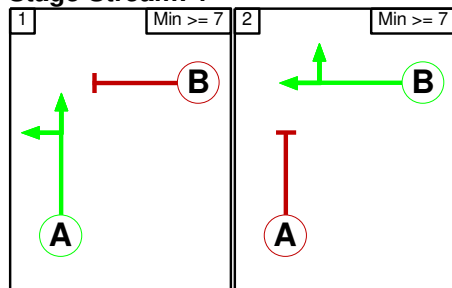

Stage Stream: 2

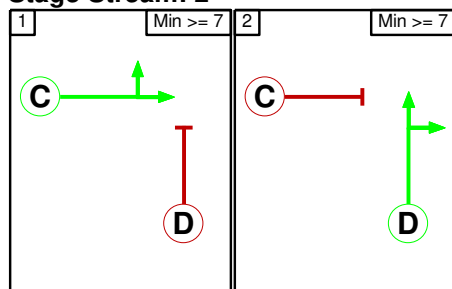

Stage Stream: 3

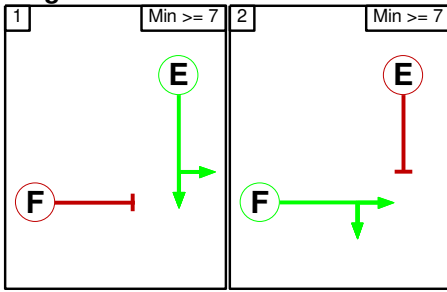

Stage Stream: 4

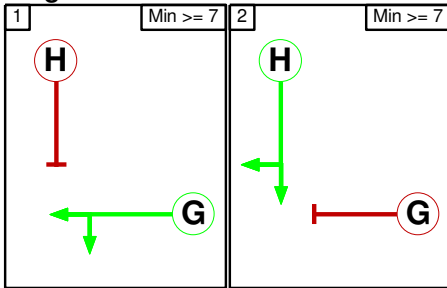

Phase Delays

Stage Stream: 1

Term. Stage	Start Stage	Phase	Type	Value	Cont value
There are no Phase Delays defined					

Stage Stream: 2

Term. Stage	Start Stage	Phase	Type	Value	Cont value
There are no Phase Delays defined					

Stage Stream: 3

Term. Stage	Start Stage	Phase	Type	Value	Cont value
There are no Phase Delays defined					

Stage Stream: 4

Term. Stage	Start Stage	Phase	Type	Value	Cont value
There are no Phase Delays defined					

Prohibited Stage Change

Stage Stream: 1

		To Stage	
		1	2
From Stage	1		6
	2	6	

Stage Stream: 2

		To Stage	
		1	2
From Stage	1		6
	2	6	

Stage Stream: 3

	To Stage		
From Stage		1	2
	1		6
	2	6	

Stage Stream: 4

	To Stage		
From Stage		1	2
	1		6
	2	6	

Give-Way Lane Input Data

Junction: J1: M1 Junction 14											
Lane	Movement	Max Flow when Giving Way (PCU/Hr)	Min Flow when Giving Way (PCU/Hr)	Opposing Lane	Opp. Lane Coeff.	Opp. Mvmnts.	Right Turn Storage (PCU)	Non-Blocking Storage (PCU)	RTF	Right Turn Move up (s)	Max Turns in Intergreen (PCU)
J1:5/1 (A509 London Road)	J1:10/1 (Left)	1000	0	J1:4/1	0.33	All					
				J1:4/2	0.33	All					
J1:5/2 (A509 London Road)	J1:10/2 (Left)	1000	0	J1:4/1	0.33	All	-	-	-	-	-
				J1:4/2	0.33	All					
				J1:4/3	0.33	All					
J1:5/2 (A509 London Road)	J1:7/1 (Ahead)	1000	0	J1:4/1	0.33	All	-	-	-	-	-
				J1:4/2	0.33	All					
J1:5/3 (A509 London Road)	J1:7/2 (Ahead)	1000	0	J1:4/3	0.33	All	-	-	-	-	-
				J1:4/1	0.33	All					
				J1:4/2	0.33	All					

Junction: J2: Northfields Roundabout

There are no Opposed Lanes in this Junction

Lane Input Data

Junction: J1: M1 Junction 14												
Lane	Lane Type	Phases	Start Disp.	End Disp.	Physical Length (PCU)	Sat Flow Type	Def User Saturation Flow (PCU/Hr)	Lane Width (m)	Gradient	Nearside Lane	Turns	Turning Radius (m)
J1:1/1 (A509 (S))	U	A	2	3	19.1	Geom	-	3.50	0.00	Y	Arm J1:12 Left	Inf
J1:1/2 (A509 (S))	U	A	2	3	60.0	Geom	-	3.50	0.00	N	Arm J1:2 Ahead	Inf
											Arm J1:12 Left	Inf
J1:1/3 (A509 (S))	U	A	2	3	60.0	Geom	-	3.50	0.00	Y	Arm J1:2 Ahead	Inf
J1:2/1	U	D	2	3	31.3	User	1900	-	-	-	-	-
J1:2/2	U	D	2	3	31.3	User	1900	-	-	-	-	-
J1:3/1 (M1 S/B Off-Slip)	U	C	2	3	23.5	Geom	-	3.50	0.00	Y	Arm J1:9 Left	20.00
J1:3/2 (M1 S/B Off-Slip)	U	C	2	3	60.0	Geom	-	3.50	0.00	N	Arm J1:4 Ahead	Inf
J1:3/3 (M1 S/B Off-Slip)	U	C	2	3	60.0	Geom	-	3.50	0.00	N	Arm J1:4 Ahead	Inf
J1:4/1	U		2	3	7.0	Inf	-	-	-	-	-	-
J1:4/2	U		2	3	7.0	Inf	-	-	-	-	-	-
J1:4/3	U		2	3	7.0	Inf	-	-	-	-	-	-
J1:5/1 (A509 London Road)	O		2	3	10.8	Geom	-	3.50	0.00	Y	Arm J1:10 Left	30.00
J1:5/2 (A509 London Road)	O		2	3	60.0	Geom	-	3.50	0.00	N	Arm J1:7 Ahead	Inf
J1:5/3 (A509 London Road)	O		2	3	9.0	Geom	-	3.50	0.00	N	Arm J1:7 Ahead	Inf
J1:6/1 (M1 N/B Off-Slip)	U		2	3	60.0	Inf	-	-	-	-	-	-
J1:6/2 (M1 N/B Off-Slip)	U	F	2	3	60.0	User	1800	-	-	-	-	-
J1:7/1	U	E	2	3	31.3	User	1900	-	-	-	-	-
J1:7/2	U	E	2	3	31.3	User	1900	-	-	-	-	-
J1:7/3	U	E	2	3	3.0	User	1900	-	-	-	-	-
J1:8/1	U	B	2	3	8.2	User	1900	-	-	-	-	-
J1:8/2	U	B	2	3	8.2	User	1900	-	-	-	-	-
J1:8/3	U	B	2	3	2.6	Geom	-	3.50	0.00	Y	Arm J1:2 Right	25.00

J1:9/1	U		2	3	7.0	Inf	-	-	-	-	-	-
J1:10/1	U		2	3	7.0	Inf	-	-	-	-	-	-
J1:10/2	U		2	3	7.0	Inf	-	-	-	-	-	-
J1:11/1	U		2	3	7.0	Inf	-	-	-	-	-	-
J1:11/2	U		2	3	7.0	Inf	-	-	-	-	-	-
J1:11/3	U		2	3	7.0	Inf	-	-	-	-	-	-
J1:12/1	U		2	3	7.0	Inf	-	-	-	-	-	-
J1:12/2	U		2	3	7.0	Inf	-	-	-	-	-	-

Junction: J2: Northfields Roundabout												
Lane	Lane Type	Phases	Start Disp.	End Disp.	Physical Length (PCU)	Sat Flow Type	Def User Saturation Flow (PCU/Hr)	Lane Width (m)	Gradient	Nearside Lane	Turns	Turning Radius (m)
J2:1/1 (A4145 Childs Way (S))	U	A	2	3	60.0	Geom	-	3.50	0.00	Y	Arm J2:2 Ahead	Inf
											Arm J2:9 Left	Inf
J2:1/2 (A4145 Childs Way (S))	U	A	2	3	60.0	Geom	-	3.50	0.00	N	Arm J2:2 Ahead	Inf
J2:1/3 (A4145 Childs Way (S))	U	A	2	3	12.2	Geom	-	3.50	0.00	Y	Arm J2:2 Ahead	Inf
J2:2/1	U	D	2	3	8.7	User	1900	-	-	-	-	-
J2:2/2	U	D	2	3	8.7	User	1900	-	-	-	-	-
J2:2/3	U	D	2	3	8.7	User	1900	-	-	-	-	-
J2:3/1 (A509 (W))	U	C	2	3	60.0	Geom	-	3.50	0.00	Y	Arm J2:10 Left	Inf
J2:3/2 (A509 (W))	U	C	2	3	60.0	Geom	-	3.50	0.00	N	Arm J2:10 Left	Inf
J2:3/3 (A509 (W))	U	C	2	3	17.4	Geom	-	3.50	0.00	Y	Arm J2:5 Ahead	Inf
J2:4/1 (A509 (N))	U	E	2	3	60.0	Geom	-	3.50	0.00	Y	Arm J2:6 Ahead	Inf
											Arm J2:11 Left	Inf
J2:4/2 (A509 (N))	U	E	2	3	60.0	Geom	-	3.50	0.00	N	Arm J2:6 Ahead	Inf
J2:4/3 (A509 (N))	U	E	2	3	60.0	Geom	-	3.50	0.00	N	Arm J2:6 Ahead	Inf
J2:4/4 (A509 (N))	U	E	2	3	5.2	Geom	-	3.50	0.00	Y	Arm J2:6 Ahead	Inf
J2:5/1	U	F	2	3	11.3	User	1900	-	-	-	-	-
J2:5/2	U	F	2	3	11.3	User	1900	-	-	-	-	-
J2:5/3	U	F	2	3	11.3	User	1900	-	-	-	-	-
J2:6/1	U	H	2	3	8.7	User	1900	-	-	-	-	-
J2:6/2	U	H	2	3	8.7	User	1900	-	-	-	-	-
J2:6/3	U	H	2	3	8.7	User	1900	-	-	-	-	-
J2:6/4	U	H	2	3	8.7	User	1900	-	-	-	-	-
J2:7/1 (A5130 (E))	U	G	2	3	60.0	Geom	-	3.50	0.00	Y	Arm J2:8 Ahead	Inf
											Arm J2:12 Left	Inf
J2:7/2 (A5130 (E))	U	G	2	3	60.0	Geom	-	3.50	0.00	N	Arm J2:8 Ahead	Inf

J2:7/3 (A5130 (E))	U	G	2	3	7.0	Geom	-	3.50	0.00	Y	Arm J2:8 Ahead	Inf
J2:8/1	U	B	2	3	11.3	User	1900	-	-	-	-	-
J2:8/2	U	B	2	3	11.3	User	1900	-	-	-	-	-
J2:8/3	U	B	2	3	11.3	User	1900	-	-	-	-	-
J2:9/1	U		2	3	5.2	Inf	-	-	-	-	-	-
J2:9/2	U		2	3	5.2	Inf	-	-	-	-	-	-
J2:10/1	U		2	3	5.2	Inf	-	-	-	-	-	-
J2:10/2	U		2	3	5.2	Inf	-	-	-	-	-	-
J2:11/1	U		2	3	5.2	Inf	-	-	-	-	-	-
J2:11/2	U		2	3	5.2	Inf	-	-	-	-	-	-
J2:12/1	U		2	3	60.0	Inf	-	-	-	-	-	-
J2:12/2	U		2	3	60.0	Inf	-	-	-	-	-	-

Traffic Flow Groups

Flow Group	Start Time	End Time	Duration	Formula
4: '2023 Bkgd AM'	08:00	09:00	01:00	
5: '2023 WD AM'	08:00	09:00	01:00	
11: '2023 Bkgd PM'	17:00	18:00	01:00	
12: '2023 WD PM'	17:00	18:00	01:00	

Scenario 3: '2023 Bkgd AM' (FG4: '2023 Bkgd AM', Plan 1: '2017 Observed AM')

Traffic Flows, Desired

Desired Flow :

	Destination							
	A	B	C	D	E	F	Tot.	
Origin	A	4	250	0	637	100	798	1789
	B	152	12	353	265	42	332	1156
	C	2	314	8	637	100	798	1859
	D	395	162	249	5	187	17	1015
	E	138	57	87	427	2	122	833
	F	427	175	269	4	46	4	925
	Tot.	1118	970	966	1975	477	2071	7577

Traffic Lane Flows

Lane	Scenario 3: 2023 Bkgd AM
Junction: J1: M1 Junction 14	
J1:1/1 (short)	767
J1:1/2 (with short)	1441(In) 674(Out)
J1:1/3	518
J1:2/1	807
J1:2/2	526
J1:3/1 (short)	250
J1:3/2 (with short)	1035(In) 785(Out)
J1:3/3	754
J1:4/1	351
J1:4/2	1047
J1:4/3	754
J1:5/1	353
J1:5/2 (with short)	803(In) 374(Out)
J1:5/3 (short)	429
J1:6/1	1535
J1:6/2	324
J1:7/1	1159
J1:7/2 (with short)	1183(In) 1099(Out)
J1:7/3 (short)	84
J1:8/1	84
J1:8/2 (with short)	408(In) 400(Out)
J1:8/3 (short)	8
J1:9/1	970
J1:10/1	527
J1:10/2	439
J1:11/1	1060
J1:11/2	1110
J1:11/3	1539
J1:12/1	851
J1:12/2	267
Junction: J2: Northfields Roundabout	
J2:1/1	421
J2:1/2 (with short)	504(In) 454(Out)
J2:1/3 (short)	50

J2:2/1	576
J2:2/2	577
J2:2/3	52
J2:3/1	388
J2:3/2	418
J2:3/3	209
J2:4/1	1060
J2:4/2	1110
J2:4/3 (with short)	1539(In) 772(Out)
J2:4/4 (short)	767
J2:5/1	131
J2:5/2	120
J2:5/3	10
J2:6/1	834
J2:6/2	1115
J2:6/3	775
J2:6/4	769
J2:7/1	338
J2:7/2 (with short)	495(In) 370(Out)
J2:7/3 (short)	125
J2:8/1	991
J2:8/2	1139
J2:8/3	125
J2:9/1	993
J2:9/2	982
J2:10/1	964
J2:10/2	995
J2:11/1	252
J2:11/2	225
J2:12/1	895
J2:12/2	1176

Lane Saturation Flows

Junction: J1: M1 Junction 14								
Lane	Lane Width (m)	Gradient	Nearside Lane	Allowed Turns	Turning Radius (m)	Turning Prop.	Sat Flow (PCU/Hr)	Flared Sat Flow (PCU/Hr)
J1:1/1 (A509 (S))	3.50	0.00	Y	Arm J1:12 Left	Inf	100.0 %	1965	1965
J1:1/2 (A509 (S))	3.50	0.00	N	Arm J1:2 Ahead Arm J1:12 Left	Inf Inf	71.4 % 28.6 %	2105	2105
J1:1/3 (A509 (S))	3.50	0.00	Y	Arm J1:2 Ahead	Inf	100.0 %	1965	1965
J1:2/1	This lane uses a directly entered Saturation Flow						1900	1900
J1:2/2	This lane uses a directly entered Saturation Flow						1900	1900
J1:3/1 (M1 S/B Off-Slip)	3.50	0.00	Y	Arm J1:9 Left	20.00	100.0 %	1828	1828
J1:3/2 (M1 S/B Off-Slip)	3.50	0.00	N	Arm J1:4 Ahead	Inf	100.0 %	2105	2105
J1:3/3 (M1 S/B Off-Slip)	3.50	0.00	N	Arm J1:4 Ahead	Inf	100.0 %	2105	2105
J1:4/1	Infinite Saturation Flow						Inf	Inf
J1:4/2	Infinite Saturation Flow						Inf	Inf
J1:4/3	Infinite Saturation Flow						Inf	Inf
J1:5/1 (A509 London Road)	3.50	0.00	Y	Arm J1:10 Left	30.00	100.0 %	1871	1871
J1:5/2 (A509 London Road)	3.50	0.00	N	Arm J1:7 Ahead	Inf	100.0 %	2105	2105
J1:5/3 (A509 London Road)	3.50	0.00	N	Arm J1:7 Ahead	Inf	100.0 %	2105	2105
J1:6/1 (M1 N/B Off-Slip Lane 1)	Infinite Saturation Flow						Inf	Inf
J1:6/2 (M1 N/B Off-Slip Lane 2)	This lane uses a directly entered Saturation Flow						1800	1800
J1:7/1	This lane uses a directly entered Saturation Flow						1900	1900
J1:7/2	This lane uses a directly entered Saturation Flow						1900	1900
J1:7/3	This lane uses a directly entered Saturation Flow						1900	1900
J1:8/1	This lane uses a directly entered Saturation Flow						1900	1900
J1:8/2	This lane uses a directly entered Saturation Flow						1900	1900
J1:8/3	3.50	0.00	Y	Arm J1:2 Right	25.00	100.0 %	1854	1854
J1:9/1	Infinite Saturation Flow						Inf	Inf
J1:10/1	Infinite Saturation Flow						Inf	Inf
J1:10/2	Infinite Saturation Flow						Inf	Inf
J1:11/1	Infinite Saturation Flow						Inf	Inf
J1:11/2	Infinite Saturation Flow						Inf	Inf
J1:11/3	Infinite Saturation Flow						Inf	Inf
J1:12/1	Infinite Saturation Flow						Inf	Inf
J1:12/2	Infinite Saturation Flow						Inf	Inf

Junction: J2: Northfields Roundabout								
Lane	Lane Width (m)	Gradient	Nearside Lane	Allowed Turns	Turning Radius (m)	Turning Prop.	Sat Flow (PCU/Hr)	Flared Sat Flow (PCU/Hr)
J2:1/1 (A4145 Childs Way (S))	3.50	0.00	Y	Arm J2:2 Ahead	Inf	99.0 %	1965	1965
				Arm J2:9 Left	Inf	1.0 %		
J2:1/2 (A4145 Childs Way (S))	3.50	0.00	N	Arm J2:2 Ahead	Inf	100.0 %	2105	2105
J2:1/3 (A4145 Childs Way (S))	3.50	0.00	Y	Arm J2:2 Ahead	Inf	100.0 %	1965	1965
J2:2/1	This lane uses a directly entered Saturation Flow						1900	1900
J2:2/2	This lane uses a directly entered Saturation Flow						1900	1900
J2:2/3	This lane uses a directly entered Saturation Flow						1900	1900
J2:3/1 (A509 (W))	3.50	0.00	Y	Arm J2:10 Left	Inf	100.0 %	1965	1965
J2:3/2 (A509 (W))	3.50	0.00	N	Arm J2:10 Left	Inf	100.0 %	2105	2105
J2:3/3 (A509 (W))	3.50	0.00	Y	Arm J2:5 Ahead	Inf	100.0 %	1965	1965
J2:4/1 (A509 (N))	3.50	0.00	Y	Arm J2:6 Ahead	Inf	77.2 %	1965	1965
				Arm J2:11 Left	Inf	22.8 %		
J2:4/2 (A509 (N))	3.50	0.00	N	Arm J2:6 Ahead	Inf	100.0 %	2105	2105
J2:4/3 (A509 (N))	3.50	0.00	N	Arm J2:6 Ahead	Inf	100.0 %	2105	2105
J2:4/4 (A509 (N))	3.50	0.00	Y	Arm J2:6 Ahead	Inf	100.0 %	1965	1965
J2:5/1	This lane uses a directly entered Saturation Flow						1900	1900
J2:5/2	This lane uses a directly entered Saturation Flow						1900	1900
J2:5/3	This lane uses a directly entered Saturation Flow						1900	1900
J2:6/1	This lane uses a directly entered Saturation Flow						1900	1900
J2:6/2	This lane uses a directly entered Saturation Flow						1900	1900
J2:6/3	This lane uses a directly entered Saturation Flow						1900	1900
J2:6/4	This lane uses a directly entered Saturation Flow						1900	1900
J2:7/1 (A5130 (E))	3.50	0.00	Y	Arm J2:8 Ahead	Inf	63.9 %	1965	1965
				Arm J2:12 Left	Inf	36.1 %		
J2:7/2 (A5130 (E))	3.50	0.00	N	Arm J2:8 Ahead	Inf	100.0 %	2105	2105
J2:7/3 (A5130 (E))	3.50	0.00	Y	Arm J2:8 Ahead	Inf	100.0 %	1965	1965
J2:8/1	This lane uses a directly entered Saturation Flow						1900	1900
J2:8/2	This lane uses a directly entered Saturation Flow						1900	1900
J2:8/3	This lane uses a directly entered Saturation Flow						1900	1900
J2:9/1	Infinite Saturation Flow						Inf	Inf
J2:9/2	Infinite Saturation Flow						Inf	Inf
J2:10/1	Infinite Saturation Flow						Inf	Inf
J2:10/2	Infinite Saturation Flow						Inf	Inf

J2:11/1	Infinite Saturation Flow	Inf	Inf
J2:11/2	Infinite Saturation Flow	Inf	Inf
J2:12/1	Infinite Saturation Flow	Inf	Inf
J2:12/2	Infinite Saturation Flow	Inf	Inf

Scenario 4: '2023 WD AM' (FG5: '2023 WD AM', Plan 1: '2017 Observed AM')

Traffic Flows, Desired

Desired Flow :

		Destination						
		A	B	C	D	E	F	Tot.
Origin	A	4	281	0	656	96	803	1840
	B	152	12	368	273	40	334	1179
	C	2	314	8	669	98	819	1910
	D	389	157	241	4	184	18	993
	E	139	56	86	426	2	123	832
	F	427	175	269	4	46	4	925
	Tot.	1113	995	972	2032	466	2101	7679

Traffic Lane Flows

Lane	Scenario 4: 2023 WD AM
Junction: J1: M1 Junction 14	
J1:1/1 (short)	824
J1:1/2 (with short)	1433(In) 609(Out)
J1:1/3	506
J1:2/1	804
J1:2/2	514
J1:3/1 (short)	281
J1:3/2 (with short)	1082(In) 801(Out)
J1:3/3	758
J1:4/1	347
J1:4/2	1058
J1:4/3	758
J1:5/1	368
J1:5/2 (with short)	811(In) 374(Out)
J1:5/3 (short)	437
J1:6/1	1586
J1:6/2	324
J1:7/1	1175
J1:7/2 (with short)	1195(In) 1111(Out)
J1:7/3 (short)	84
J1:8/1	84
J1:8/2 (with short)	408(In) 400(Out)
J1:8/3 (short)	8
J1:9/1	995
J1:10/1	531
J1:10/2	441
J1:11/1	1068
J1:11/2	1122
J1:11/3	1598
J1:12/1	908
J1:12/2	205
Junction: J2: Northfields Roundabout	
J2:1/1	421
J2:1/2 (with short)	504(In) 454(Out)
J2:1/3 (short)	50

J2:2/1	572
J2:2/2	580
J2:2/3	52
J2:3/1	378
J2:3/2	409
J2:3/3	206
J2:4/1	1068
J2:4/2	1122
J2:4/3 (with short)	1598(In) 840(Out)
J2:4/4 (short)	758
J2:5/1	131
J2:5/2	117
J2:5/3	10
J2:6/1	850
J2:6/2	1128
J2:6/3	843
J2:6/4	759
J2:7/1	335
J2:7/2 (with short)	497(In) 369(Out)
J2:7/3 (short)	128
J2:8/1	1055
J2:8/2	1128
J2:8/3	128
J2:9/1	1057
J2:9/2	975
J2:10/1	950
J2:10/2	989
J2:11/1	248
J2:11/2	218
J2:12/1	911
J2:12/2	1190

Lane Saturation Flows

Junction: J1: M1 Junction 14								
Lane	Lane Width (m)	Gradient	Nearside Lane	Allowed Turns	Turning Radius (m)	Turning Prop.	Sat Flow (PCU/Hr)	Flared Sat Flow (PCU/Hr)
J1:1/1 (A509 (S))	3.50	0.00	Y	Arm J1:12 Left	Inf	100.0 %	1965	1965
J1:1/2 (A509 (S))	3.50	0.00	N	Arm J1:2 Ahead Arm J1:12 Left	Inf Inf	78.5 % 21.5 %	2105	2105
J1:1/3 (A509 (S))	3.50	0.00	Y	Arm J1:2 Ahead	Inf	100.0 %	1965	1965
J1:2/1	This lane uses a directly entered Saturation Flow						1900	1900
J1:2/2	This lane uses a directly entered Saturation Flow						1900	1900
J1:3/1 (M1 S/B Off-Slip)	3.50	0.00	Y	Arm J1:9 Left	20.00	100.0 %	1828	1828
J1:3/2 (M1 S/B Off-Slip)	3.50	0.00	N	Arm J1:4 Ahead	Inf	100.0 %	2105	2105
J1:3/3 (M1 S/B Off-Slip)	3.50	0.00	N	Arm J1:4 Ahead	Inf	100.0 %	2105	2105
J1:4/1	Infinite Saturation Flow						Inf	Inf
J1:4/2	Infinite Saturation Flow						Inf	Inf
J1:4/3	Infinite Saturation Flow						Inf	Inf
J1:5/1 (A509 London Road)	3.50	0.00	Y	Arm J1:10 Left	30.00	100.0 %	1871	1871
J1:5/2 (A509 London Road)	3.50	0.00	N	Arm J1:7 Ahead	Inf	100.0 %	2105	2105
J1:5/3 (A509 London Road)	3.50	0.00	N	Arm J1:7 Ahead	Inf	100.0 %	2105	2105
J1:6/1 (M1 N/B Off-Slip Lane 1)	Infinite Saturation Flow						Inf	Inf
J1:6/2 (M1 N/B Off-Slip Lane 2)	This lane uses a directly entered Saturation Flow						1800	1800
J1:7/1	This lane uses a directly entered Saturation Flow						1900	1900
J1:7/2	This lane uses a directly entered Saturation Flow						1900	1900
J1:7/3	This lane uses a directly entered Saturation Flow						1900	1900
J1:8/1	This lane uses a directly entered Saturation Flow						1900	1900
J1:8/2	This lane uses a directly entered Saturation Flow						1900	1900
J1:8/3	3.50	0.00	Y	Arm J1:2 Right	25.00	100.0 %	1854	1854
J1:9/1	Infinite Saturation Flow						Inf	Inf
J1:10/1	Infinite Saturation Flow						Inf	Inf
J1:10/2	Infinite Saturation Flow						Inf	Inf
J1:11/1	Infinite Saturation Flow						Inf	Inf
J1:11/2	Infinite Saturation Flow						Inf	Inf
J1:11/3	Infinite Saturation Flow						Inf	Inf
J1:12/1	Infinite Saturation Flow						Inf	Inf
J1:12/2	Infinite Saturation Flow						Inf	Inf

Junction: J2: Northfields Roundabout								
Lane	Lane Width (m)	Gradient	Nearside Lane	Allowed Turns	Turning Radius (m)	Turning Prop.	Sat Flow (PCU/Hr)	Flared Sat Flow (PCU/Hr)
J2:1/1 (A4145 Childs Way (S))	3.50	0.00	Y	Arm J2:2 Ahead	Inf	99.0 %	1965	1965
				Arm J2:9 Left	Inf	1.0 %		
J2:1/2 (A4145 Childs Way (S))	3.50	0.00	N	Arm J2:2 Ahead	Inf	100.0 %	2105	2105
J2:1/3 (A4145 Childs Way (S))	3.50	0.00	Y	Arm J2:2 Ahead	Inf	100.0 %	1965	1965
J2:2/1	This lane uses a directly entered Saturation Flow						1900	1900
J2:2/2	This lane uses a directly entered Saturation Flow						1900	1900
J2:2/3	This lane uses a directly entered Saturation Flow						1900	1900
J2:3/1 (A509 (W))	3.50	0.00	Y	Arm J2:10 Left	Inf	100.0 %	1965	1965
J2:3/2 (A509 (W))	3.50	0.00	N	Arm J2:10 Left	Inf	100.0 %	2105	2105
J2:3/3 (A509 (W))	3.50	0.00	Y	Arm J2:5 Ahead	Inf	100.0 %	1965	1965
J2:4/1 (A509 (N))	3.50	0.00	Y	Arm J2:6 Ahead	Inf	78.1 %	1965	1965
				Arm J2:11 Left	Inf	21.9 %		
J2:4/2 (A509 (N))	3.50	0.00	N	Arm J2:6 Ahead	Inf	100.0 %	2105	2105
J2:4/3 (A509 (N))	3.50	0.00	N	Arm J2:6 Ahead	Inf	100.0 %	2105	2105
J2:4/4 (A509 (N))	3.50	0.00	Y	Arm J2:6 Ahead	Inf	100.0 %	1965	1965
J2:5/1	This lane uses a directly entered Saturation Flow						1900	1900
J2:5/2	This lane uses a directly entered Saturation Flow						1900	1900
J2:5/3	This lane uses a directly entered Saturation Flow						1900	1900
J2:6/1	This lane uses a directly entered Saturation Flow						1900	1900
J2:6/2	This lane uses a directly entered Saturation Flow						1900	1900
J2:6/3	This lane uses a directly entered Saturation Flow						1900	1900
J2:6/4	This lane uses a directly entered Saturation Flow						1900	1900
J2:7/1 (A5130 (E))	3.50	0.00	Y	Arm J2:8 Ahead	Inf	63.3 %	1965	1965
				Arm J2:12 Left	Inf	36.7 %		
J2:7/2 (A5130 (E))	3.50	0.00	N	Arm J2:8 Ahead	Inf	100.0 %	2105	2105
J2:7/3 (A5130 (E))	3.50	0.00	Y	Arm J2:8 Ahead	Inf	100.0 %	1965	1965
J2:8/1	This lane uses a directly entered Saturation Flow						1900	1900
J2:8/2	This lane uses a directly entered Saturation Flow						1900	1900
J2:8/3	This lane uses a directly entered Saturation Flow						1900	1900
J2:9/1	Infinite Saturation Flow						Inf	Inf
J2:9/2	Infinite Saturation Flow						Inf	Inf
J2:10/1	Infinite Saturation Flow						Inf	Inf
J2:10/2	Infinite Saturation Flow						Inf	Inf

J2:11/1	Infinite Saturation Flow	Inf	Inf
J2:11/2	Infinite Saturation Flow	Inf	Inf
J2:12/1	Infinite Saturation Flow	Inf	Inf
J2:12/2	Infinite Saturation Flow	Inf	Inf

Scenario 9: '2023 Bkgd PM' (FG11: '2023 Bkgd PM', Plan 1: '2017 Observed AM')

Traffic Flows, Desired

Desired Flow :

		Destination						
		A	B	C	D	E	F	Tot.
Origin	A	2	267	0	283	86	468	1106
	B	246	32	374	156	47	258	1113
	C	0	408	16	239	73	396	1132
	D	639	284	483	4	256	7	1673
	E	201	89	152	253	1	116	812
	F	551	245	417	2	54	6	1275
	Tot.	1639	1325	1442	937	517	1251	7111

Traffic Lane Flows

Lane	Scenario 9: 2023 Bkgd PM
Junction: J1: M1 Junction 14	
J1:1/1 (short)	717
J1:1/2 (with short)	2025(In) 1308(Out)
J1:1/3	1036
J1:2/1	1090
J1:2/2	1036
J1:3/1 (short)	267
J1:3/2 (with short)	713(In) 446(Out)
J1:3/3	393
J1:4/1	551
J1:4/2	963
J1:4/3	393
J1:5/1	374
J1:5/2 (with short)	739(In) 305(Out)
J1:5/3 (short)	434
J1:6/1	708
J1:6/2	424
J1:7/1	751
J1:7/2 (with short)	827(In) 795(Out)
J1:7/3 (short)	32
J1:8/1	248
J1:8/2 (with short)	456(In) 456(Out)
J1:8/3 (short)	0
J1:9/1	1325
J1:10/1	738
J1:10/2	704
J1:11/1	693
J1:11/2	635
J1:11/3	678
J1:12/1	965
J1:12/2	674
Junction: J2: Northfields Roundabout	
J2:1/1	737
J2:1/2 (with short)	538(In) 478(Out)
J2:1/3 (short)	60

J2:2/1	756
J2:2/2	899
J2:2/3	61
J2:3/1	677
J2:3/2	729
J2:3/3	267
J2:4/1	693
J2:4/2	635
J2:4/3 (with short)	678(In) 189(Out)
J2:4/4 (short)	489
J2:5/1	140
J2:5/2	171
J2:5/3	17
J2:6/1	487
J2:6/2	648
J2:6/3	190
J2:6/4	492
J2:7/1	368
J2:7/2 (with short)	444(In) 22(Out)
J2:7/3 (short)	422
J2:8/1	442
J2:8/2	514
J2:8/3	422
J2:9/1	443
J2:9/2	494
J2:10/1	1433
J2:10/2	1628
J2:11/1	242
J2:11/2	275
J2:12/1	545
J2:12/2	706

Lane Saturation Flows

Junction: J1: M1 Junction 14								
Lane	Lane Width (m)	Gradient	Nearside Lane	Allowed Turns	Turning Radius (m)	Turning Prop.	Sat Flow (PCU/Hr)	Flared Sat Flow (PCU/Hr)
J1:1/1 (A509 (S))	3.50	0.00	Y	Arm J1:12 Left	Inf	100.0 %	1965	1965
J1:1/2 (A509 (S))	3.50	0.00	N	Arm J1:2 Ahead Arm J1:12 Left	Inf Inf	48.5 % 51.5 %	2105	2105
J1:1/3 (A509 (S))	3.50	0.00	Y	Arm J1:2 Ahead	Inf	100.0 %	1965	1965
J1:2/1	This lane uses a directly entered Saturation Flow						1900	1900
J1:2/2	This lane uses a directly entered Saturation Flow						1900	1900
J1:3/1 (M1 S/B Off-Slip)	3.50	0.00	Y	Arm J1:9 Left	20.00	100.0 %	1828	1828
J1:3/2 (M1 S/B Off-Slip)	3.50	0.00	N	Arm J1:4 Ahead	Inf	100.0 %	2105	2105
J1:3/3 (M1 S/B Off-Slip)	3.50	0.00	N	Arm J1:4 Ahead	Inf	100.0 %	2105	2105
J1:4/1	Infinite Saturation Flow						Inf	Inf
J1:4/2	Infinite Saturation Flow						Inf	Inf
J1:4/3	Infinite Saturation Flow						Inf	Inf
J1:5/1 (A509 London Road)	3.50	0.00	Y	Arm J1:10 Left	30.00	100.0 %	1871	1871
J1:5/2 (A509 London Road)	3.50	0.00	N	Arm J1:7 Ahead	Inf	100.0 %	2105	2105
J1:5/3 (A509 London Road)	3.50	0.00	N	Arm J1:7 Ahead	Inf	100.0 %	2105	2105
J1:6/1 (M1 N/B Off-Slip Lane 1)	Infinite Saturation Flow						Inf	Inf
J1:6/2 (M1 N/B Off-Slip Lane 2)	This lane uses a directly entered Saturation Flow						1800	1800
J1:7/1	This lane uses a directly entered Saturation Flow						1900	1900
J1:7/2	This lane uses a directly entered Saturation Flow						1900	1900
J1:7/3	This lane uses a directly entered Saturation Flow						1900	1900
J1:8/1	This lane uses a directly entered Saturation Flow						1900	1900
J1:8/2	This lane uses a directly entered Saturation Flow						1900	1900
J1:8/3	3.50	0.00	Y	Arm J1:2 Right	25.00	0.0 %	1965	1965
J1:9/1	Infinite Saturation Flow						Inf	Inf
J1:10/1	Infinite Saturation Flow						Inf	Inf
J1:10/2	Infinite Saturation Flow						Inf	Inf
J1:11/1	Infinite Saturation Flow						Inf	Inf
J1:11/2	Infinite Saturation Flow						Inf	Inf
J1:11/3	Infinite Saturation Flow						Inf	Inf
J1:12/1	Infinite Saturation Flow						Inf	Inf
J1:12/2	Infinite Saturation Flow						Inf	Inf

Junction: J2: Northfields Roundabout								
Lane	Lane Width (m)	Gradient	Nearside Lane	Allowed Turns	Turning Radius (m)	Turning Prop.	Sat Flow (PCU/Hr)	Flared Sat Flow (PCU/Hr)
J2:1/1 (A4145 Childs Way (S))	3.50	0.00	Y	Arm J2:2 Ahead	Inf	99.7 %	1965	1965
				Arm J2:9 Left	Inf	0.3 %		
J2:1/2 (A4145 Childs Way (S))	3.50	0.00	N	Arm J2:2 Ahead	Inf	100.0 %	2105	2105
J2:1/3 (A4145 Childs Way (S))	3.50	0.00	Y	Arm J2:2 Ahead	Inf	100.0 %	1965	1965
J2:2/1	This lane uses a directly entered Saturation Flow						1900	1900
J2:2/2	This lane uses a directly entered Saturation Flow						1900	1900
J2:2/3	This lane uses a directly entered Saturation Flow						1900	1900
J2:3/1 (A509 (W))	3.50	0.00	Y	Arm J2:10 Left	Inf	100.0 %	1965	1965
J2:3/2 (A509 (W))	3.50	0.00	N	Arm J2:10 Left	Inf	100.0 %	2105	2105
J2:3/3 (A509 (W))	3.50	0.00	Y	Arm J2:5 Ahead	Inf	100.0 %	1965	1965
J2:4/1 (A509 (N))	3.50	0.00	Y	Arm J2:6 Ahead	Inf	70.3 %	1965	1965
				Arm J2:11 Left	Inf	29.7 %		
J2:4/2 (A509 (N))	3.50	0.00	N	Arm J2:6 Ahead	Inf	100.0 %	2105	2105
J2:4/3 (A509 (N))	3.50	0.00	N	Arm J2:6 Ahead	Inf	100.0 %	2105	2105
J2:4/4 (A509 (N))	3.50	0.00	Y	Arm J2:6 Ahead	Inf	100.0 %	1965	1965
J2:5/1	This lane uses a directly entered Saturation Flow						1900	1900
J2:5/2	This lane uses a directly entered Saturation Flow						1900	1900
J2:5/3	This lane uses a directly entered Saturation Flow						1900	1900
J2:6/1	This lane uses a directly entered Saturation Flow						1900	1900
J2:6/2	This lane uses a directly entered Saturation Flow						1900	1900
J2:6/3	This lane uses a directly entered Saturation Flow						1900	1900
J2:6/4	This lane uses a directly entered Saturation Flow						1900	1900
J2:7/1 (A5130 (E))	3.50	0.00	Y	Arm J2:8 Ahead	Inf	68.5 %	1965	1965
				Arm J2:12 Left	Inf	31.5 %		
J2:7/2 (A5130 (E))	3.50	0.00	N	Arm J2:8 Ahead	Inf	100.0 %	2105	2105
J2:7/3 (A5130 (E))	3.50	0.00	Y	Arm J2:8 Ahead	Inf	100.0 %	1965	1965
J2:8/1	This lane uses a directly entered Saturation Flow						1900	1900
J2:8/2	This lane uses a directly entered Saturation Flow						1900	1900
J2:8/3	This lane uses a directly entered Saturation Flow						1900	1900
J2:9/1	Infinite Saturation Flow						Inf	Inf
J2:9/2	Infinite Saturation Flow						Inf	Inf
J2:10/1	Infinite Saturation Flow						Inf	Inf
J2:10/2	Infinite Saturation Flow						Inf	Inf

J2:11/1	Infinite Saturation Flow	Inf	Inf
J2:11/2	Infinite Saturation Flow	Inf	Inf
J2:12/1	Infinite Saturation Flow	Inf	Inf
J2:12/2	Infinite Saturation Flow	Inf	Inf

Scenario 10: '2023 WD PM' (FG12: '2023 WD PM', Plan 1: '2017 Observed AM')

Traffic Flows, Desired

Desired Flow :

		Destination						
		A	B	C	D	E	F	Tot.
Origin	A	2	286	0	288	86	463	1125
	B	246	32	403	159	47	256	1143
	C	0	408	16	250	74	403	1151
	D	660	287	489	4	256	7	1703
	E	204	89	151	253	1	116	814
	F	557	243	413	2	54	6	1275
	Tot.	1669	1345	1472	956	518	1251	7211

Traffic Lane Flows

Lane	Scenario 10: 2023 WD PM
Junction: J1: M1 Junction 14	
J1:1/1 (short)	716
J1:1/2 (with short)	2061(In) 1345(Out)
J1:1/3	1032
J1:2/1	1096
J1:2/2	1032
J1:3/1 (short)	286
J1:3/2 (with short)	733(In) 447(Out)
J1:3/3	392
J1:4/1	553
J1:4/2	963
J1:4/3	392
J1:5/1	403
J1:5/2 (with short)	740(In) 303(Out)
J1:5/3 (short)	437
J1:6/1	727
J1:6/2	424
J1:7/1	750
J1:7/2 (with short)	829(In) 797(Out)
J1:7/3 (short)	32
J1:8/1	248
J1:8/2 (with short)	456(In) 456(Out)
J1:8/3 (short)	0
J1:9/1	1345
J1:10/1	754
J1:10/2	718
J1:11/1	698
J1:11/2	631
J1:11/3	697
J1:12/1	964
J1:12/2	705
Junction: J2: Northfields Roundabout	
J2:1/1	737
J2:1/2 (with short)	538(In) 478(Out)
J2:1/3 (short)	60

J2:2/1	749
J2:2/2	908
J2:2/3	61
J2:3/1	692
J2:3/2	744
J2:3/3	267
J2:4/1	698
J2:4/2	631
J2:4/3 (with short)	697(In) 182(Out)
J2:4/4 (short)	515
J2:5/1	146
J2:5/2	165
J2:5/3	17
J2:6/1	491
J2:6/2	644
J2:6/3	184
J2:6/4	517
J2:7/1	368
J2:7/2 (with short)	446(In) 15(Out)
J2:7/3 (short)	431
J2:8/1	436
J2:8/2	532
J2:8/3	431
J2:9/1	437
J2:9/2	519
J2:10/1	1441
J2:10/2	1652
J2:11/1	249
J2:11/2	269
J2:12/1	549
J2:12/2	702

Lane Saturation Flows

Junction: J1: M1 Junction 14								
Lane	Lane Width (m)	Gradient	Nearside Lane	Allowed Turns	Turning Radius (m)	Turning Prop.	Sat Flow (PCU/Hr)	Flared Sat Flow (PCU/Hr)
J1:1/1 (A509 (S))	3.50	0.00	Y	Arm J1:12 Left	Inf	100.0 %	1965	1965
J1:1/2 (A509 (S))	3.50	0.00	N	Arm J1:2 Ahead Arm J1:12 Left	Inf Inf	47.6 % 52.4 %	2105	2105
J1:1/3 (A509 (S))	3.50	0.00	Y	Arm J1:2 Ahead	Inf	100.0 %	1965	1965
J1:2/1	This lane uses a directly entered Saturation Flow						1900	1900
J1:2/2	This lane uses a directly entered Saturation Flow						1900	1900
J1:3/1 (M1 S/B Off-Slip)	3.50	0.00	Y	Arm J1:9 Left	20.00	100.0 %	1828	1828
J1:3/2 (M1 S/B Off-Slip)	3.50	0.00	N	Arm J1:4 Ahead	Inf	100.0 %	2105	2105
J1:3/3 (M1 S/B Off-Slip)	3.50	0.00	N	Arm J1:4 Ahead	Inf	100.0 %	2105	2105
J1:4/1	Infinite Saturation Flow						Inf	Inf
J1:4/2	Infinite Saturation Flow						Inf	Inf
J1:4/3	Infinite Saturation Flow						Inf	Inf
J1:5/1 (A509 London Road)	3.50	0.00	Y	Arm J1:10 Left	30.00	100.0 %	1871	1871
J1:5/2 (A509 London Road)	3.50	0.00	N	Arm J1:7 Ahead	Inf	100.0 %	2105	2105
J1:5/3 (A509 London Road)	3.50	0.00	N	Arm J1:7 Ahead	Inf	100.0 %	2105	2105
J1:6/1 (M1 N/B Off-Slip Lane 1)	Infinite Saturation Flow						Inf	Inf
J1:6/2 (M1 N/B Off-Slip Lane 2)	This lane uses a directly entered Saturation Flow						1800	1800
J1:7/1	This lane uses a directly entered Saturation Flow						1900	1900
J1:7/2	This lane uses a directly entered Saturation Flow						1900	1900
J1:7/3	This lane uses a directly entered Saturation Flow						1900	1900
J1:8/1	This lane uses a directly entered Saturation Flow						1900	1900
J1:8/2	This lane uses a directly entered Saturation Flow						1900	1900
J1:8/3	3.50	0.00	Y	Arm J1:2 Right	25.00	0.0 %	1965	1965
J1:9/1	Infinite Saturation Flow						Inf	Inf
J1:10/1	Infinite Saturation Flow						Inf	Inf
J1:10/2	Infinite Saturation Flow						Inf	Inf
J1:11/1	Infinite Saturation Flow						Inf	Inf
J1:11/2	Infinite Saturation Flow						Inf	Inf
J1:11/3	Infinite Saturation Flow						Inf	Inf
J1:12/1	Infinite Saturation Flow						Inf	Inf
J1:12/2	Infinite Saturation Flow						Inf	Inf

Junction: J2: Northfields Roundabout								
Lane	Lane Width (m)	Gradient	Nearside Lane	Allowed Turns	Turning Radius (m)	Turning Prop.	Sat Flow (PCU/Hr)	Flared Sat Flow (PCU/Hr)
J2:1/1 (A4145 Childs Way (S))	3.50	0.00	Y	Arm J2:2 Ahead	Inf	99.7 %	1965	1965
				Arm J2:9 Left	Inf	0.3 %		
J2:1/2 (A4145 Childs Way (S))	3.50	0.00	N	Arm J2:2 Ahead	Inf	100.0 %	2105	2105
J2:1/3 (A4145 Childs Way (S))	3.50	0.00	Y	Arm J2:2 Ahead	Inf	100.0 %	1965	1965
J2:2/1	This lane uses a directly entered Saturation Flow						1900	1900
J2:2/2	This lane uses a directly entered Saturation Flow						1900	1900
J2:2/3	This lane uses a directly entered Saturation Flow						1900	1900
J2:3/1 (A509 (W))	3.50	0.00	Y	Arm J2:10 Left	Inf	100.0 %	1965	1965
J2:3/2 (A509 (W))	3.50	0.00	N	Arm J2:10 Left	Inf	100.0 %	2105	2105
J2:3/3 (A509 (W))	3.50	0.00	Y	Arm J2:5 Ahead	Inf	100.0 %	1965	1965
J2:4/1 (A509 (N))	3.50	0.00	Y	Arm J2:6 Ahead	Inf	70.3 %	1965	1965
				Arm J2:11 Left	Inf	29.7 %		
J2:4/2 (A509 (N))	3.50	0.00	N	Arm J2:6 Ahead	Inf	100.0 %	2105	2105
J2:4/3 (A509 (N))	3.50	0.00	N	Arm J2:6 Ahead	Inf	100.0 %	2105	2105
J2:4/4 (A509 (N))	3.50	0.00	Y	Arm J2:6 Ahead	Inf	100.0 %	1965	1965
J2:5/1	This lane uses a directly entered Saturation Flow						1900	1900
J2:5/2	This lane uses a directly entered Saturation Flow						1900	1900
J2:5/3	This lane uses a directly entered Saturation Flow						1900	1900
J2:6/1	This lane uses a directly entered Saturation Flow						1900	1900
J2:6/2	This lane uses a directly entered Saturation Flow						1900	1900
J2:6/3	This lane uses a directly entered Saturation Flow						1900	1900
J2:6/4	This lane uses a directly entered Saturation Flow						1900	1900
J2:7/1 (A5130 (E))	3.50	0.00	Y	Arm J2:8 Ahead	Inf	68.5 %	1965	1965
				Arm J2:12 Left	Inf	31.5 %		
J2:7/2 (A5130 (E))	3.50	0.00	N	Arm J2:8 Ahead	Inf	100.0 %	2105	2105
J2:7/3 (A5130 (E))	3.50	0.00	Y	Arm J2:8 Ahead	Inf	100.0 %	1965	1965
J2:8/1	This lane uses a directly entered Saturation Flow						1900	1900
J2:8/2	This lane uses a directly entered Saturation Flow						1900	1900
J2:8/3	This lane uses a directly entered Saturation Flow						1900	1900
J2:9/1	Infinite Saturation Flow						Inf	Inf
J2:9/2	Infinite Saturation Flow						Inf	Inf
J2:10/1	Infinite Saturation Flow						Inf	Inf
J2:10/2	Infinite Saturation Flow						Inf	Inf

J2:11/1	Infinite Saturation Flow	Inf	Inf
J2:11/2	Infinite Saturation Flow	Inf	Inf
J2:12/1	Infinite Saturation Flow	Inf	Inf
J2:12/2	Infinite Saturation Flow	Inf	Inf

Scenario 3: '2023 Bkgd AM' (FG4: '2023 Bkgd AM', Plan 1: '2017 Observed AM')

C1

Stage Timings

Stage Stream: 1

Stage	1	2
Duration	31	17
Change Point	12	49

Stage Stream: 2

Stage	1	2
Duration	23	25
Change Point	54	23

Stage Stream: 3

Stage	1	2
Duration	9	39
Change Point	54	9

Signal Timings Diagram

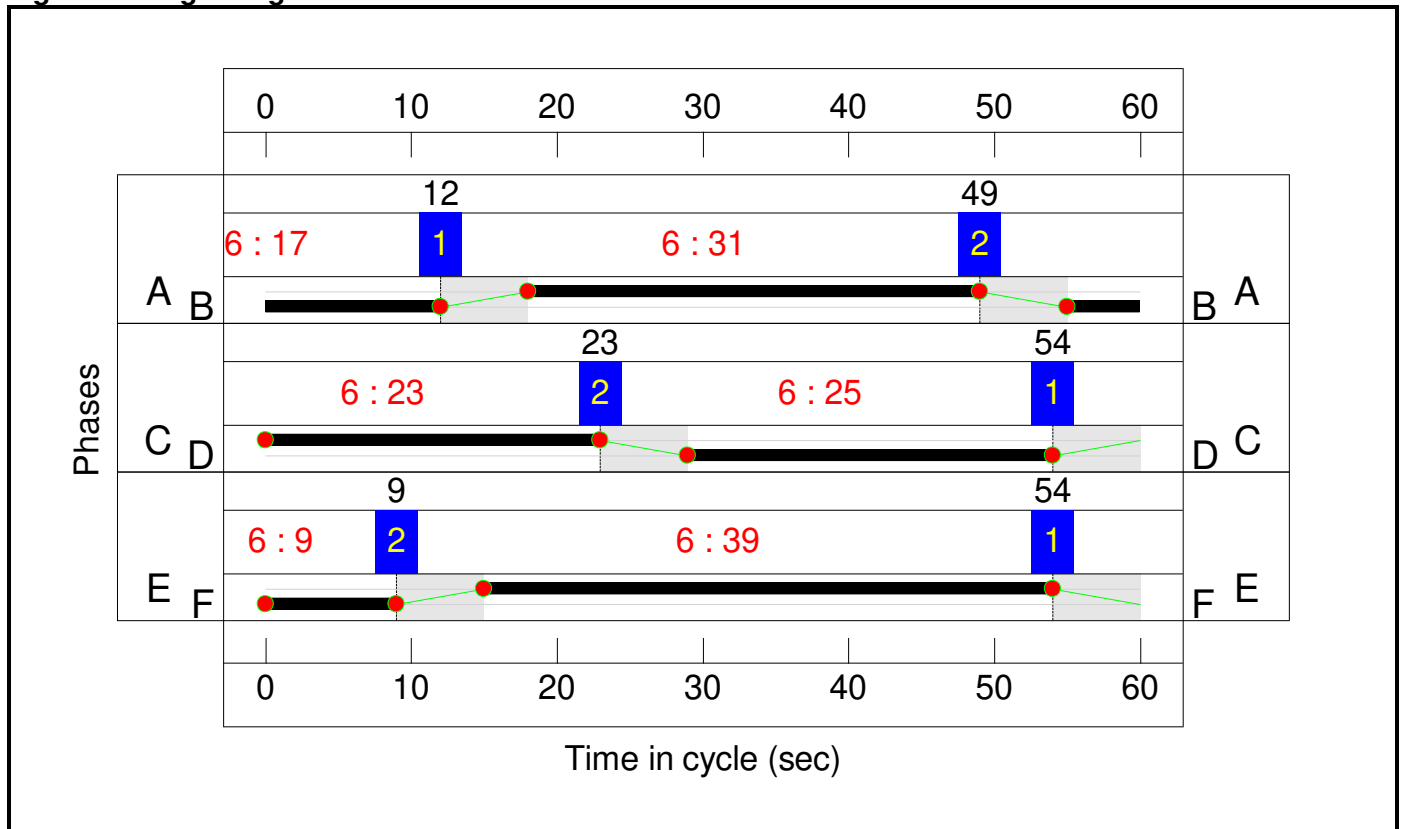

C2

Stage Timings

Stage Stream: 1

Stage	1	2
Duration	9	39
Change Point	33	48

Stage Stream: 2

Stage	1	2
Duration	12	36
Change Point	46	4

Stage Stream: 3

Stage	1	2
Duration	38	10
Change Point	0	44

Stage Stream: 4

Stage	1	2
Duration	10	38
Change Point	47	3

Signal Timings Diagram

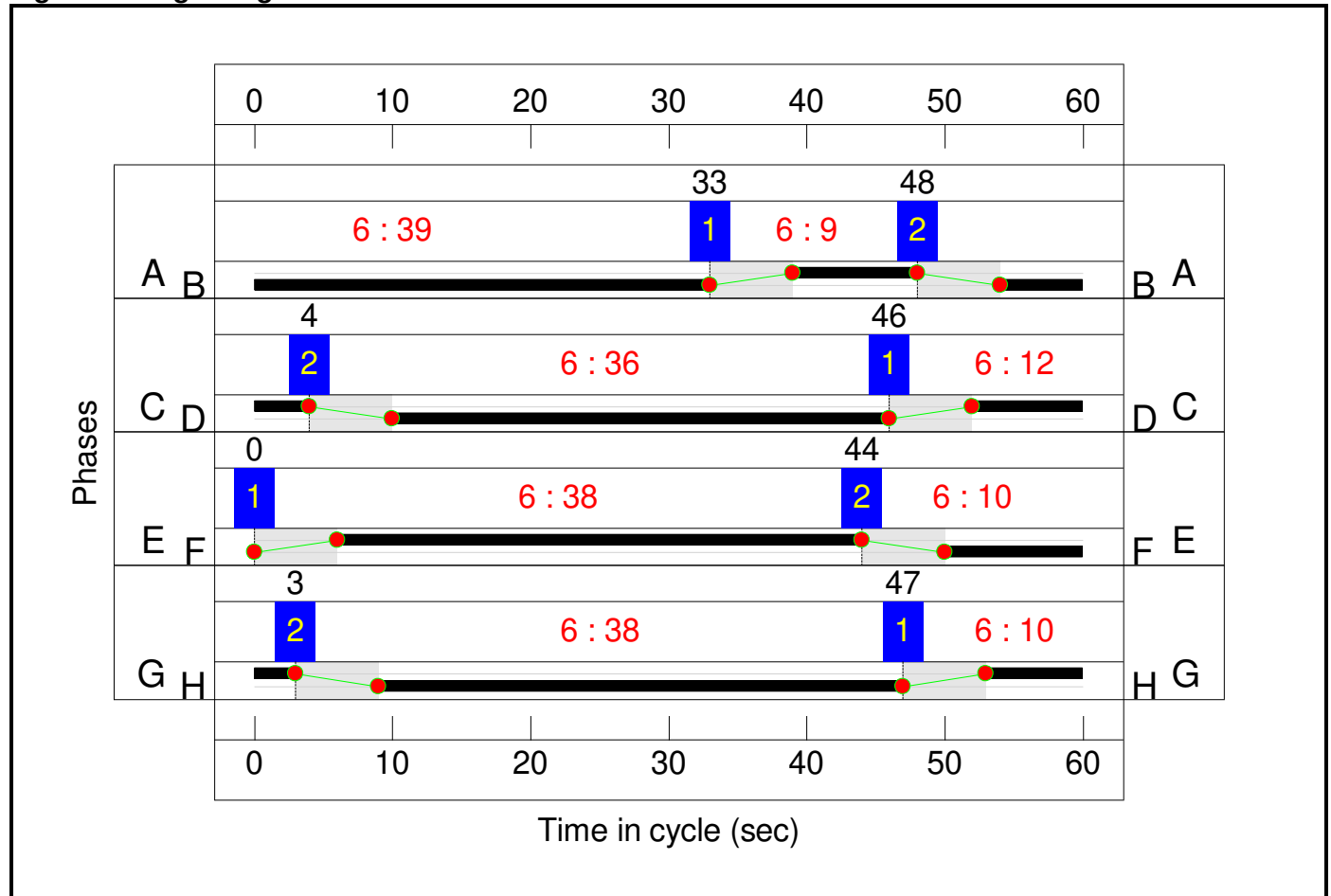

Network Results

Item	Lane Description	Lane Type	Controller Stream	Position In Filtered Route	Full Phase	Arrow Phase	Num Greens	Total Green (s)	Arrow Green (s)	Demand Flow (pcu)	Sat Flow (pcu/Hr)	Capacity (pcu)	Deg Sat (%)
Network: M1 Junction 14 / Northfields Roundabout Model	-	-	N/A	-	-		-	-	-	-	-	-	129.4%
J1: M1 Junction 14	-	-	N/A	-	-		-	-	-	-	-	-	108.0%
1/2+1/1	A509 (S) Ahead Left	U	1:1	N/A	C1:A		1	31	-	1441	2105:1965	931+1048	64.8 : 65.3%
1/3	A509 (S) Ahead	U	1:1	N/A	C1:A		1	31	-	518	1965	1048	45.4%
2/1	Right Ahead	U	1:2	N/A	C1:D		1	25	-	807	1900	823	88.2%
2/2	Right	U	1:2	N/A	C1:D		1	25	-	526	1900	823	58.7%
3/2+3/1	M1 S/B Off-Slip Ahead Left	U	1:2	N/A	C1:C		1	23	-	1035	2105:1828	842+276	93.2 : 90.7%
3/3	M1 S/B Off-Slip Ahead	U	1:2	N/A	C1:C		1	23	-	754	2105	842	89.5%
5/1	A509 London Road Left	O	N/A	N/A	-		-	-	-	353	1871	445	79.4%
5/2+5/3	A509 London Road Ahead	O	N/A	N/A	-		-	-	-	803	2105:2105	440+440	85.1 : 97.6%
6/2	M1 N/B Off-Slip Ahead	U	1:3	N/A	C1:F		1	9	-	324	1800	300	108.0%
7/1	Ahead	U	1:3	N/A	C1:E		1	39	-	1159	1900	1267	91.5%
7/2+7/3	Right Ahead	U	1:3	N/A	C1:E		1	39	-	1183	1900:1900	1180+90	93.1 : 93.1%
8/1	Ahead	U	1:1	N/A	C1:B		1	17	-	84	1900	570	14.7%
8/2+8/3	Right Ahead	U	1:1	N/A	C1:B		1	17	-	408	1900:1854	570+11	66.1 : 65.0%
J2: Northfields Roundabout	-	-	N/A	-	-		-	-	-	-	-	-	129.4%
1/1	A4145 Childs Way (S) Ahead Left	U	2:1	N/A	C2:A		1	9	-	421	1965	327	128.5%
1/2+1/3	A4145 Childs Way (S) Ahead	U	2:1	N/A	C2:A		1	9	-	504	2105:1965	351+39	129.4 : 129.4%
2/1	Ahead	U	2:2	N/A	C2:D		1	36	-	576	1900	1172	41.3%

2/2	Ahead	U	2:2	N/A	C2:D		1	36	-	577	1900	1172	40.4%
2/3	Right	U	2:2	N/A	C2:D		1	36	-	52	1900	1172	4.4%
3/1	A509 (W) Left	U	2:2	N/A	C2:C		1	12	-	388	1965	426	91.1%
3/2	A509 (W) Left	U	2:2	N/A	C2:C		1	12	-	418	2105	456	91.6%
3/3	A509 (W) Ahead	U	2:2	N/A	C2:C		1	12	-	209	1965	426	49.1%
4/1	A509 (N) Ahead Left	U	2:3	N/A	C2:E		1	38	-	1060	1965	1277	83.0%
4/2	A509 (N) Ahead	U	2:3	N/A	C2:E		1	38	-	1110	2105	1368	81.1%
4/3+4/4	A509 (N) Ahead	U	2:3	N/A	C2:E		1	38	-	1539	2105:1965	819+814	94.2 : 94.2%
5/1	Ahead	U	2:3	N/A	C2:F		1	10	-	131	1900	348	37.6%
5/2	Right Ahead	U	2:3	N/A	C2:F		1	10	-	120	1900	348	34.4%
5/3	Right	U	2:3	N/A	C2:F		1	10	-	10	1900	348	2.9%
6/1	Ahead	U	2:4	N/A	C2:H		1	38	-	834	1900	1235	67.5%
6/2	Ahead	U	2:4	N/A	C2:H		1	38	-	1115	1900	1235	90.3%
6/3	Right	U	2:4	N/A	C2:H		1	38	-	775	1900	1235	62.8%
6/4	Right	U	2:4	N/A	C2:H		1	38	-	769	1900	1235	62.3%
7/1	A5130 (E) Ahead Left	U	2:4	N/A	C2:G		1	10	-	338	1965	360	93.8%
7/2+7/3	A5130 (E) Ahead	U	2:4	N/A	C2:G		1	10	-	495	2105:1965	386+130	95.9 : 95.9%
8/1	Ahead	U	2:1	N/A	C2:B		1	39	-	991	1900	1267	78.2%
8/2	Right Ahead	U	2:1	N/A	C2:B		1	39	-	1139	1900	1267	89.9%
8/3	Right	U	2:1	N/A	C2:B		1	39	-	125	1900	1267	9.9%

Item	Arriving (pcu)	Leaving (pcu)	Turners In Gaps (pcu)	Turners When Unopposed (pcu)	Turners In Intergreen (pcu)	Uniform Delay (pcuHr)	Rand + Oversat Delay (pcuHr)	Storage Area Uniform Delay (pcuHr)	Total Delay (pcuHr)	Av. Delay Per PCU (s/pcu)	Max. Back of Uniform Queue (pcu)	Rand + Oversat Queue (pcu)	Mean Max Queue (pcu)
Network: M1 Junction 14 / Northfields Roundabout Model	-	-	1959	0	0	67.0	175.4	0.0	242.4	-	-	-	-
J1: M1 Junction 14	-	-	1959	0	0	26.1	34.1	0.0	60.2	-	-	-	-
1/2+1/1	1288	1288	-	-	-	3.1	0.9	-	4.1	11.3	24.5	0.9	25.4
1/3	476	476	-	-	-	1.2	0.4	-	1.6	12.5	6.7	0.4	7.1
2/1	726	726	-	-	-	1.8	0.0	-	1.8	9.0	11.7	0.0	11.7
2/2	483	483	-	-	-	0.1	0.0	-	0.1	0.4	0.2	0.0	0.2
3/2+3/1	1035	1035	-	-	-	4.6	5.5	-	10.1	35.3	12.4	5.5	17.9
3/3	754	754	-	-	-	3.5	3.9	-	7.5	35.6	11.7	3.9	15.7
5/1	353	353	353	0	0	0.9	1.9	-	2.7	27.7	5.0	1.9	6.9
5/2+5/3	803	803	1606	0	0	2.5	4.7	-	7.2	32.1	6.9	4.7	11.6
6/2	324	300	-	-	-	3.0	16.8	-	19.8	220.3	5.8	16.8	22.6
7/1	1159	1159	-	-	-	2.1	0.0	-	2.1	6.5	18.8	0.0	18.8
7/2+7/3	1183	1183	-	-	-	2.2	0.0	-	2.2	6.7	18.5	0.0	18.5
8/1	84	84	-	-	-	0.5	0.0	-	0.5	21.9	1.4	0.0	1.4
8/2+8/3	384	384	-	-	-	0.5	0.0	-	0.5	5.0	1.4	0.0	1.4
J2: Northfields Roundabout	-	-	0	0	0	40.9	141.2	0.0	182.2	-	-	-	-
1/1	421	327	-	-	-	5.4	48.9	-	54.3	464.0	9.1	48.9	58.0
1/2+1/3	504	401	-	-	-	5.6	59.4	-	65.0	464.1	9.3	59.4	68.7
2/1	483	483	-	-	-	1.5	0.0	-	1.5	11.5	5.9	0.0	5.9
2/2	474	474	-	-	-	2.0	0.0	-	2.0	15.1	5.8	0.0	5.8
2/3	52	52	-	-	-	0.0	0.0	-	0.0	2.2	0.5	0.0	0.5
3/1	388	388	-	-	-	2.5	4.2	-	6.7	61.9	6.3	4.2	10.5
3/2	418	418	-	-	-	2.7	4.4	-	7.1	61.3	6.7	4.4	11.2
3/3	209	209	-	-	-	1.2	0.5	-	1.7	28.9	3.0	0.5	3.5
4/1	1060	1060	-	-	-	2.7	2.4	-	5.1	17.3	11.0	2.4	13.4

4/2	1110	1110	-	-	-	3.1	2.1	-	5.2	17.0	11.0	2.1	13.1
4/3+4/4	1539	1539	-	-	-	3.9	7.1	-	11.0	25.8	13.8	7.1	20.9
5/1	131	131	-	-	-	0.6	0.0	-	0.6	15.3	1.1	0.0	1.1
5/2	120	120	-	-	-	0.5	0.0	-	0.5	15.9	1.0	0.0	1.0
5/3	10	10	-	-	-	0.0	0.0	-	0.0	16.3	0.1	0.0	0.1
6/1	834	834	-	-	-	0.1	0.0	-	0.1	0.6	0.6	0.0	0.6
6/2	1115	1115	-	-	-	0.4	0.0	-	0.4	1.2	2.4	0.0	2.4
6/3	775	775	-	-	-	0.2	0.0	-	0.2	0.7	0.5	0.0	0.5
6/4	769	769	-	-	-	0.1	0.0	-	0.1	0.5	0.3	0.0	0.3
7/1	338	338	-	-	-	2.3	5.2	-	7.5	79.4	5.5	5.2	10.7
7/2+7/3	495	495	-	-	-	3.2	7.0	-	10.2	74.5	6.1	7.0	13.1
8/1	991	991	-	-	-	1.2	0.0	-	1.2	4.5	8.1	0.0	8.1
8/2	1139	1139	-	-	-	1.6	0.0	-	1.6	5.1	10.8	0.0	10.8
8/3	125	125	-	-	-	0.0	0.0	-	0.0	0.1	0.1	0.0	0.1

C1	Stream: 1	PRC for Signalled Lanes (%)	36.2	Total Delay for Signalled Lanes (pcuHr):	6.75	Cycle Time (s):	60
C1	Stream: 2	PRC for Signalled Lanes (%)	-3.6	Total Delay for Signalled Lanes (pcuHr):	19.46	Cycle Time (s):	60
C1	Stream: 3	PRC for Signalled Lanes (%)	-20.0	Total Delay for Signalled Lanes (pcuHr):	24.11	Cycle Time (s):	60
C2	Stream: 1	PRC for Signalled Lanes (%)	-43.8	Total Delay for Signalled Lanes (pcuHr):	122.10	Cycle Time (s):	60
C2	Stream: 2	PRC for Signalled Lanes (%)	-1.8	Total Delay for Signalled Lanes (pcuHr):	19.03	Cycle Time (s):	60
C2	Stream: 3	PRC for Signalled Lanes (%)	-4.7	Total Delay for Signalled Lanes (pcuHr):	22.52	Cycle Time (s):	60
C2	Stream: 4	PRC for Signalled Lanes (%)	-6.5	Total Delay for Signalled Lanes (pcuHr):	18.50	Cycle Time (s):	60
		PRC Over All Lanes (%)	-43.8	Total Delay Over All Lanes(pcuHr):	242.35		

Scenario 4: '2023 WD AM' (FG5: '2023 WD AM', Plan 1: '2017 Observed AM')

C1

Stage Timings

Stage Stream: 1

Stage	1	2
Duration	31	17
Change Point	12	49

Stage Stream: 2

Stage	1	2
Duration	23	25
Change Point	54	23

Stage Stream: 3

Stage	1	2
Duration	9	39
Change Point	54	9

Signal Timings Diagram

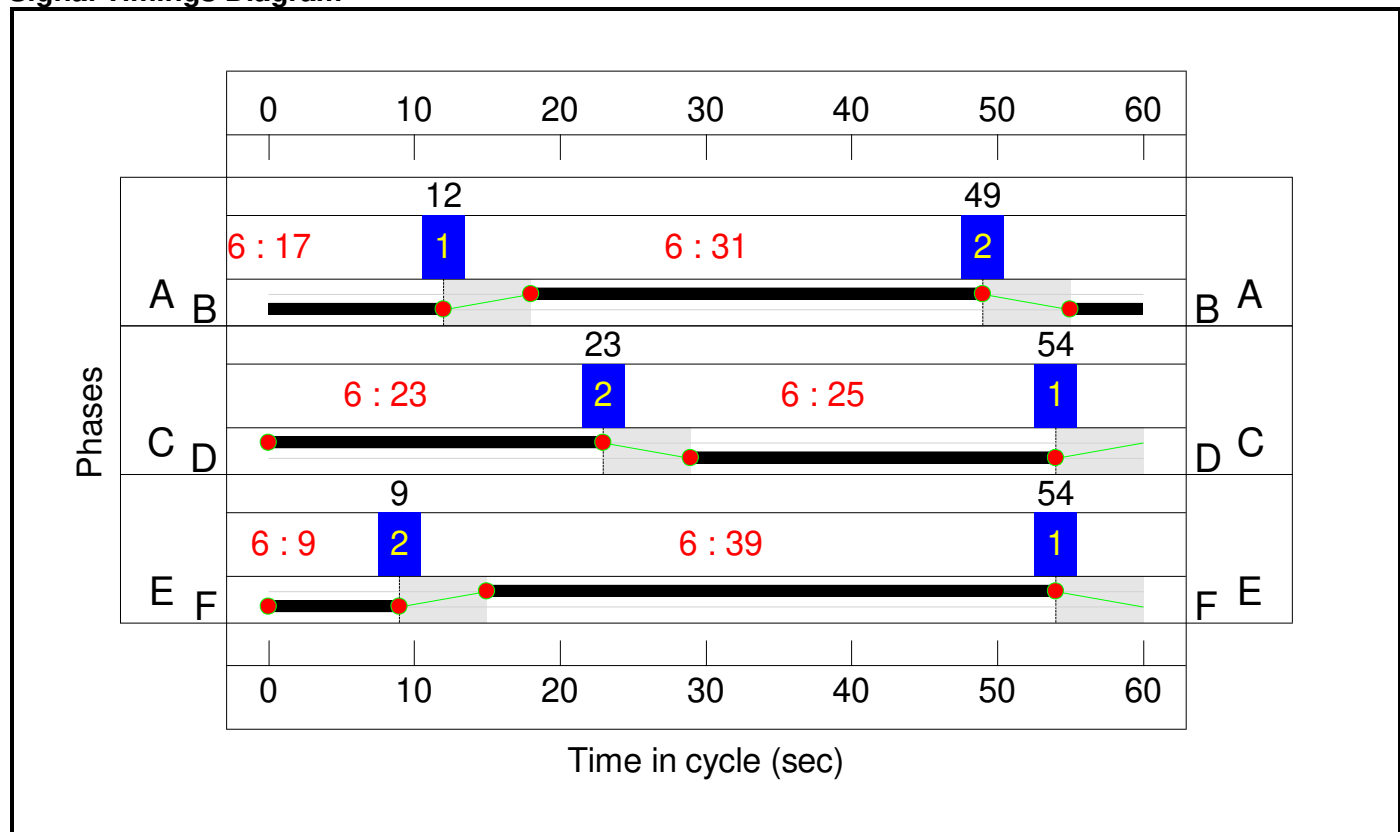

C2

Stage Timings

Stage Stream: 1

Stage	1	2
Duration	9	39
Change Point	33	48

Stage Stream: 2

Stage	1	2
Duration	12	36
Change Point	46	4

Stage Stream: 3

Stage	1	2
Duration	38	10
Change Point	0	44

Stage Stream: 4

Stage	1	2
Duration	10	38
Change Point	47	3

Signal Timings Diagram

