

Note: Isometric drawing is for reference only, details may not accurately represent actual design - please see detailed views for technical information

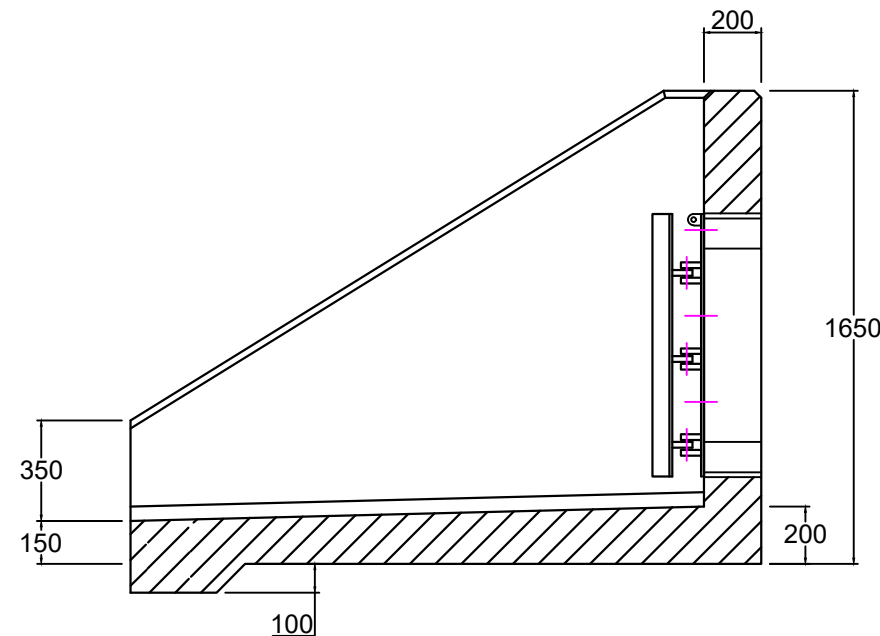
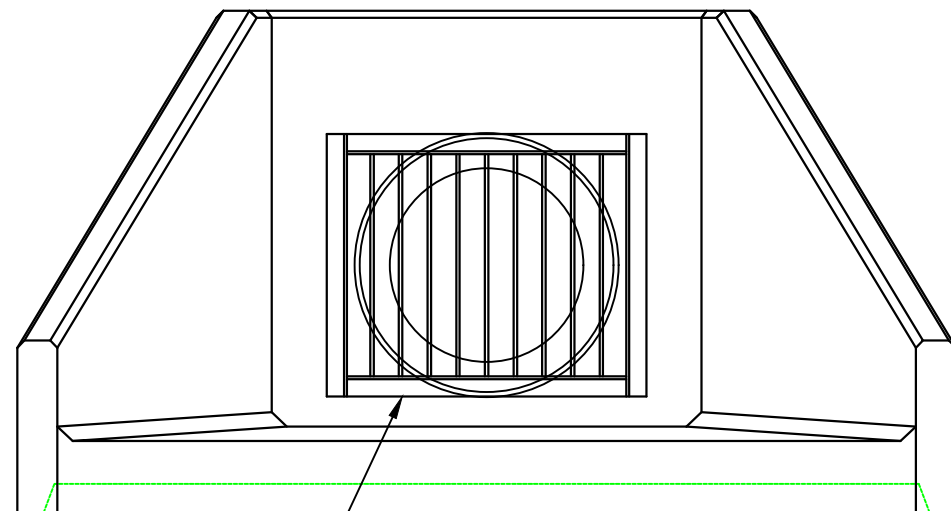
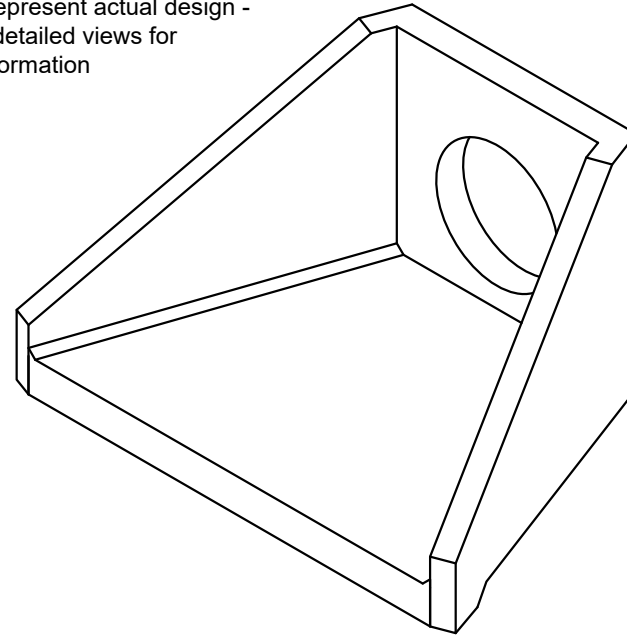

- Sewers for Adoption / Sewers for Scotland Outfall Safety Grille - SFA1 675
- In accordance with Figure C.6 Typical Outfall Safety Grille - for outfalls of 350mm diameter or greater - Sewers for Adoption 7th Edition
 - Material Grade is to be: BS EN 10025 S275
 - All mild steel to be hot dipped galvanized after fabrication
 - Galvanizing to BS EN: 1461
 - Welding to BS EN 1011-2:2001
 - Hinged on one side with padlock facility
 - Weight Approx: 95kg

DO NOT SCALE DRAWING

NOTES:

- All dimensions in mm
- All measurements ± 1mm

Specification Information

- Opening in back wall cast to suit outside diameter of the pipework
- Invert level of pipe can be set to your specification

Headwall Installation

Units should be bedded on minimum 200mm thick well compacted Class 6A* selected well graded granular material.
 *Manual of contract documents for Highway Works: Volume (MCHW1) specification for Highway Works, Series 600 (Nov.09).
 Sit the headwall level or with a slight fall 1:50 from pipe to spill mouth.

Handling

- Weight of concrete is based on 2.4 tonne/m³+5% is recommended for sizing lifting equipment.
- All lifting points shall be used as specified below
- Unit to be lifted as per lifting diagram

Concrete

- Mix ref: Self-compacting DC4/DS4 Mix
- Lifting strength based on 2 cubes = 20N/mm²
- Characteristic 28 day cube strength = 50N/mm²
- Concrete provides Design Chemical Class 4 (DC4) to special Digest 1, Table F2.

Reinforcement

- Reinforcement to BS EN 13369
- Scheduling, dimensioning, bending & cutting to BS8666
- Cage to be machine tied with steel wire

Manufacture

- Manufacture to BS EN 15258:2008 precast concrete products - Retaining wall elements, Factory Production Control certificate number: 0086-CPR-650448 & BS EN 13369
- Tolerances to BS EN 13369 clause 4.3.1.1
- Finishing:

Class	Top	Sides	Base	Rear of back wall
	A	A	A	A
				Self - Levelled
- Marking: Units shall be indelibly marked to show:
 - Mould reference code
 - De-mould date
 - Job reference number & unique product number
 - Unit weight (kg)

Design

- Concrete design to EC2
- Althon have designed the concrete units only, the site conditions should be assessed for suitability by the scheme designer
- Units are designed to withstand a vertical live load surcharge of 10kN/m²
- Weight of soil = 18kN/m³
- Angle of internal friction = 30 Deg.
- Design Life: >100 years

Min Cover	Cover Block Size (mm)	Min Cover Size (mm)	Max Cover Size (mm)
All Faces	55	50	60

Exposure Classification	Exposure induced by Carbonate	Corrosion induced by Chloride	Freeze/thaw attack	Chemical attack
All Faces	XC3/4	XD3	XF4	XA3

Fabrication Specification

- Manufacture IAW EN 1090-2 EXC CLASS 1
- Material grade is to be: BS EN 10025 S275
- Welding carried out IAW EN 1090-2 PARA 7.5.4 - 7.5.18
- All fillet and butt welds to have a minimum throat thickness of 6mm & joints to be fully welded where possible.
- Ensure vertical flats are fully welded both sides where possible.
- All sharp edges and burrs are to be removed.
- Remove all weld splatter.
- Holes by punching are permitted with reaming.
- Galvanising is carried out after fabrication to BS EN:ISO 1461

Handrail Specification

- Kee Klamp® Galvanised Size 8 Fittings
- Size 8 48.3mm OD 3.2mm Wall Thickness Galvanised Medium Duty Tube to BS EN 10255
- 360N/m Design Load at stated in BS 8118, BS 6180, BS 6399 & BS 7818, Civil Engineering Specification for the Water Industry (CESWI) 7th Edition Clause 2.60 Handrails & Balusters & The Engineering Equipment and Materials Users' Association (EEMUA) Publication 105 7th Edition Factory Stairways, Ladders and Handrails
- Other design loads available on request
- GRP/FRP Handrails also available

REV NO	DATE	DESCRIPTION



ADDRESS: ALTHON LIMITED
 VULCAN ROAD SOUTH
 NORWICH
 NR6 6AF

TEL: 01603 488700
 FAX: 01603 488598
 EMAIL: sales@althon.co.uk
 WEBSITE: www.althon.co.uk

PROPRIETARY & CONFIDENTIAL

The information contained in this drawing is the sole property of Althon Limited. Any reproduction in part or as a whole without the written permission of Althon Limited is strictly prohibited.

DRAWING TITLE / PROJECT:
SFA15B Headwall
SFA1 675 Outfall Safety Grille

CLIENT:

SCALE:	PAPER:	SHEET NO.:	DATE:
NTS	A3	01 OF 01	25 - 09 - 18

HEADWALL WEIGHT:	TOE WEIGHT:
5210kg	N/A

PRODUCT NAME: **SFA15B**

DRAWING No:

